

GSE Model 350/355

DIGITAL WEIGH INDICATOR



Technical Reference Manual

Version 2.0



Model 350/355

Technical Reference Manual

Version 2.0

GSE 350/355 Digital Weigh Indicator Technical Reference Manual

Copyright © 2004 GSE Scale Systems. All rights reserved.

Published by:

GSE Scale Systems
42860 Nine Mile Road
Novi, MI 48375
USA

Information in this *Operation Manual* is subject to change *without notice* due to correction or enhancement. The information described in this manual is solely the property of GSE. No part of this manual may be reproduced or transmitted in any form or by any means, electronic or mechanical, including photocopying and recording and sold for any monetary figure without the express written permission of GSE.

GSE Locations

GSE Scale Systems

42860 Nine Mile Road
Novi, MI 48375
U.S.A.
Phone: (800) 755-7875
www.gse-inc.com

GSE Canada, Inc.

617 East Lake Road
Airdrie, Alberta Canada T4B 2B8
Phone:(403) 948-9921
Fax: (403) 948-1449

Table of Contents

- CHAPTER 1:INTRODUCTION..... 1**
- STANDARD FEATURES..... 1
- SPECIFICATIONS..... 1
- DISPLAY..... 3
 - LED Display*..... 3
 - LCD Display*..... 3
 - Annunciators*..... 4
- 350 KEYPAD..... 4
 - Secondary Functions*..... 4
- 355 KEYPAD..... 5
- STANDARD FUNCTIONS..... 6
- WEIGH MODE FUNCTIONS..... 6
- CHAPTER 2: INDICATOR INSTALLATION..... 8**
- MOUNTING..... 8
 - Desktop Mounting*..... 8
 - Panel Mounting*..... 8
 - Permanent Mounting*..... 9
 - Outline Drawings*..... 9
- WIRING..... 11
 - Load Cell Connections*..... 11
 - Serial Port Connections*..... 11
 - Remote Key Connection*..... 12
 - Power Connection*..... 13
- CHAPTER 3: OPTION INSTALLATION 15**
- MODEL 350/355 PERIPHERAL OPTIONS..... 15
- SWIVEL BRACKET..... 16
- PANEL MOUNT KIT..... 16
- ANALOG CARD CONNECTIONS..... 18
 - Analog Board Diagnostic and Test Procedures*..... 20
- ANALOG OUTPUT SETUP..... 23
- ANALOG OUTPUT CALIBRATION..... 24
 - Entering Analog Calibration Values*..... 24
 - Analog Output Example*..... 25
- SETPOINT CARD CONNECTIONS..... 26
 - Setpoint Board Diagnostic and Test Procedures*..... 29
- RS-485 NETWORKING..... 30
 - Network Connections*..... 31
- 20 MA CURRENT LOOP OPTION..... 33
 - Installation*..... 33
 - Bi-directional*..... 33
 - Baud*..... 33
 - Active/Passive*..... 33

<i>Isolation</i>	33
<i>Max Voltage</i>	34
<i>Connections</i>	34
<i>Cable</i>	34
<i>Connected Devices</i>	34
BATTERY POWER SUPPLY	35
<i>Mounting</i>	35
<i>Pin Designations</i>	36
<i>ON/OFF Switch</i>	37
<i>Battery Charging</i>	37
<i>Temperature Sensing</i>	38
<i>Low Battery Indication</i>	38
<i>Dead Battery Shutdown</i>	38
<i>Automatic Shutdown</i>	38
SPLASH GUARD PROTECTION.....	39
INTERNATIONAL TRANSFORMER - IEC	39
<i>Specifications</i>	39
<i>Transformers Available</i>	39
<i>IEC line cords Available</i>	39
CHAPTER 4: CONFIGURATION.....	40
ENTERING THE SETUP MODE (MODEL 350)	40
ENTERING THE SETUP MODE (MODEL 355)	41
SELECTING A PARAMETER	41
CHANGING A PARAMETER VALUE	43
<i>Selection Parameters</i>	43
KEY-IN PARAMETERS	43
SAVING PARAMETERS	44
FACTORY DEFAULT	46
LIST OF PARAMETERS	47
<i>Parameter Map Details</i>	48
PRESET TRANSMIT SELECTIONS.....	53
CUSTOM TRANSMIT	55
<i>Elements of a Custom Transmit</i>	55
<i>Writing a custom transmit ASCII text file</i>	55
<i>Accessing Setup and Clearing Existing Custom Transmit</i>	55
<i>Entering ASCII Text</i>	56
<i>Entering ASCII Control Codes</i>	56
<i>Parameter Selection Numbers</i>	58
<i>Exiting Setup Mode and Saving Changes</i>	59
PARTS COUNTING	59
ANALOG OUTPUT SETUP.....	60
ANALOG OUTPUT CALIBRATION	61
<i>Entering Analog Calibration Values</i>	61
<i>Analog Output Example</i>	62
SETPOINT SETUP	63
<i>Activation Methods (General)</i>	63

<i>Pre-acts (General)</i>	64
<i>Learn Feature (General)</i>	64
<i>Pause Feature (General)</i>	64
<i>Changing Targets from the Weigh Mode (General)</i>	65
<i>Example (General)</i>	65
<i>Bargraph (General)</i>	66
FILL	68
<i>Activation Method (Fill)</i>	68
<i>Pre-acts (Fill)</i>	68
<i>Learn Feature (Fill)</i>	69
<i>Pause Feature (Fill)</i>	69
<i>Changing Targets from the Weigh Mode (Fill)</i>	69
<i>Example (Fill)</i>	69
BATCH	69
<i>Activation Method (Batch)</i>	70
<i>Pre-acts (Batch)</i>	70
<i>Learn Feature (Batch)</i>	70
<i>Pause Feature (Batch)</i>	70
<i>Changing Targets from the Weigh Mode (Batch)</i>	70
<i>Example (Batch)</i>	71
DISCHARGE	71
<i>Activation Method (Discharge)</i>	72
<i>Pre-acts (Discharge)</i>	72
<i>Learn Feature (Discharge)</i>	72
<i>Pause Feature (Discharge)</i>	72
<i>Target Changes from the Weigh Mode (Discharge)</i>	73
<i>Example (Discharge)</i>	73
BOTH	73
<i>Activation Method (Both)</i>	74
<i>Pre-acts (Both)</i>	74
<i>Learn Feature (Both)</i>	74
<i>Pause Feature (Both)</i>	74
<i>Target Changes from the Weigh Mode (Both)</i>	74
<i>Example (Both)</i>	75
INDEPENDENT SETPOINT OPERATION.....	75
<i>Setpoint Activation (Independent)</i>	76
<i>Changing Targets from the Weigh Mode (Independent)</i>	76
<i>Example (Independent)</i>	77
BARGRAPH SETUP (LCD)	77
PERCENTAGE CHECK-WEIGHING	79
<i>Setpoint Activation (Percentage Check-Weighing)</i>	80
<i>Changing Targets from the Weigh Mode (Percentage Check-Weighing)</i>	80
<i>Example (Percentage Check-Weighing)</i>	81
ABSOLUTE CHECK-WEIGHING	81
<i>Setpoint Activation (Absolute Check-Weighing)</i>	82
<i>Changing Targets from the Weigh Mode (Absolute Check-Weighing)</i>	82

<i>Example (Absolute Check-Weighing)</i>	83
REMOTE KEY OPERATION	83
REMOTE SERIAL OPERATION	83
<i>Display Capture Utility</i>	84
TIME AND DATE SETUP (MODEL 350).....	84
TIME AND DATE SETUP (MODEL 355).....	86
RS-485 MULTI-DROP NETWORK SETUP AND OPERATION	86
<i>Setup</i>	87
<i>Operation</i>	87
<i>Network Protocol</i>	87
CHAPTER 5: CALIBRATION	88
SETUP MODE CALIBRATION	88
FAST CALIBRATION.....	88
PERFORMING CALIBRATION	88
ESTABLISHING ZERO	89
<i>First Zero</i>	89
<i>Last Zero</i>	91
<i>False Zero</i>	93
<i>Only Zero</i>	95
<i>Reset Calibration</i>	96
ESTABLISHING A SPAN	98
EXITING CALIBRATION	99
CHAPTER 6: LEGAL FOR TRADE	101
NTEP REQUIREMENTS.....	101
NTEP PANEL MOUNT REQUIREMENTS	101
OMIL REQUIREMENTS	102
OTHER REQUIREMENTS.....	102
SEALING AND AUDIT TRAILS.....	103
<i>Physical Seal</i>	103
<i>Audit Trails</i>	104
CHAPTER 7: TROUBLESHOOTING	106
ERROR MESSAGES	106
<i>Operational Errors</i>	106
<i>Setup Mode Errors</i>	107
<i>Hardware Errors</i>	107
<i>Calibration Errors</i>	108
<i>Communication Errors</i>	108
<i>Miscellaneous Errors</i>	108
VIEWING SETUP	108
INFORMATION MODE PARAMETERS	109
A/D CALIBRATION PROCEDURE.....	111

CHAPTER 1:INTRODUCTION

Thank you for selecting the GSE Model 350/355 Indicator. The Model 350 and Model 355 continue the GSE tradition of *Excellence in Weighing and Counting Technology*. A properly installed and maintained Model 350 or Model 355 will provide many years of reliable, accurate performance.

The chapters of this manual focus on various aspects of the Model 350/355:

Chapter 1: Introduction	Features and Specifications.
Chapter 2: Indicator Installation	Mounting and wiring connections.
Chapter 3: Option Installation	Installing and setting up options.
Chapter 4: Configuration	Using the Model 350/355.
Chapter 5: Calibration	Calibrate the indicator to a scale.
Chapter 6: Legal for Trade	Troubleshooting help and error messages.
Chapter 7: Troubleshooting	Troubleshooting help and error messages.

Standard Features

The Model 350 and 355 include built-in functions that you can enable through the Indicator Setup. Refer to *Chapter 4: Configuration* for information on the setup and operation of the following standard functions:

- Check-weighing
- Fill, two-speed, single ingredient
- Batch, three ingredients, single-speed
- Loss-in weight, two-speed emptying
- Independent setpoints
- Parts counting
- Remote key operation
- Selectable, built-in data transmission formats
- Custom data transmissions

Specifications

PERFORMANCE

Full Scale (F.S.)	Selectable 0 to 999,990
Resolution	20-bit A/D converter, 100,000d displayed ±500,000d internal
A/D Conversion	60 Hz
Zero Track	0 – 100% of F.S.
Operating Temperature	-10°C to +40°C
Units of Measure	lb, kg, oz, g, lb oz

ELECTRICAL

Power Requirement
350 Zinc Die Cast Enclosure

Input (J4): 12 – 26VAC / 12 – 36 VDC

One of four wall mount transformers supplied:

North American:

Input: 120VAC, 30W, 60 Hz

Output: 20VAC, 800mA

United Kingdom / Ireland:

Input: 230VAC, 28W, 50 Hz

Output: 20VAC, 800mA

Continental Europe:

Input: 230VAC, 28W, 50 Hz

Output: 20VAC, 800mA

IEC 320: (table top transformer with IEC 320 receptacle)

Input: 230VAC, 28W, 50 Hz

Output: 20VAC, 800mA

350/355 Stainless Steel Enclosure

Input (J10): 85 – 265VAC, 0.5A; 50/60 Hz (internal power supply version)

Input (J3): 10 – 36VDC, minimum 0.8A w/no options or 1.25A w/options installed (internal power supply version)

Excitation Voltage	10 VDC
Excitation Current	180 mA max. / (6) 350Ω bridge
F.S. Signal Input	0.1 mV/V min – 20 mV/V max
Signal Connection	4 lead or 6 lead with sense

PROCESS CONTROL

Outputs	See OPTIONS
Remote Input	1 momentary contact closure (100ms minimum) TARE, PRINT, ZERO

COMMUNICATIONS

Serial	RS232 bi-directional serial port
Data Output	14 selectable fixed-format transmissions or 1 custom format (programmable via RS232)
Protocol	Selectable
Baud Rate	150 – 9600 bps

DISPLAY

LED	6-digit weight display, 0.8” (22mm) height 11 LED annunciators for operational status
LCD	6-digit weight display, 1.0” (25.4mm) height 11 LCD annunciators for operational status Built in LCD status bargraph

ENCLOSURE

Zinc Die Cast	Black powder coat paint, self-standing on flat surface
Wall/Ceiling Mount	Optional stainless steel swivel bracket
Shipping Weight	7 lb (3 kg)
Stainless	Washdown stainless steel enclosure w/stainless steel swivel bracket (table, wall or ceiling mount)

OPTIONS

Analog Output Module	0–10 VDC/5mA, 0–20mA/10V, 4–20mA/10V, electrically isolated, 16 bit resolution with up to 10 updates per second response time, mounts internal to enclosure
Relay Output Module	Three (3) solid-state 24–280 VAC, 1A with up to 10 updates per second response time, mounts internal to enclosure or three (3) 3– 60 VDC, 2A

Wall Mount Kit	Swivel bracket/stand for zinc die cast enclosure
Panel Mount Kit	Mounts zinc die cast enclosure to user panel
	Cutout: 7.33" – 7.45" w x 5.25" – 5.37" h x 2.25" d
	186.2 – 189.2mm x 133.4 – 136.4mm x 57.2mm
Two Option Mount Kit	Mounts up to two option boards inside the stainless enclosure
Battery Power Supply Kits	Two versions: one mounts inside the stainless steel enclosure, the other mounts inside the die cast enclosure
Splash Shield	Durable adhesive plastic that adheres to the front surface of the stainless steel enclosure model
20 mA Current Loop	Enables the communication port to be a digital 20 mA current loop port.

Display

The Model 350 and Model 355 indicators are available with either a six digit, 7-segment green LED display, a six digit, 7-segment black LCD display or a 7-segment backlit LCD display. The Model 350 and Model 355 will display alphanumeric data, but due to the nature of 7-segment LEDs/LCD and the limitation of six digits, some information is abbreviated.

All segments and annunciators are illuminated for a brief display test upon power up. The current gross weight is then displayed in default units.

LED DISPLAY

The LED display is a six digit, 7-segment bright green LED screen with 12 annunciators to show weight and status information. The SP1, SP2, and SP3 annunciators are red, green, and yellow. Also there is an annunciator for a third unit under kg. Place the third unit label above the third annunciator (the third unit is available on both the LED and LCD displays). See page 49 for third unit setup.

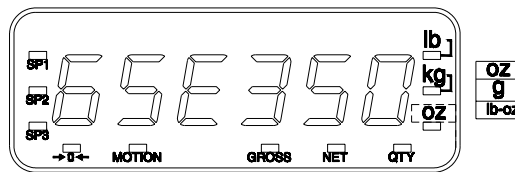

Figure 1: Model 350/355 LED Display

LCD DISPLAY

The LCD display is a six digit, 7-segment black LCD screen with 12 annunciators and a bargraph to show the operational status.

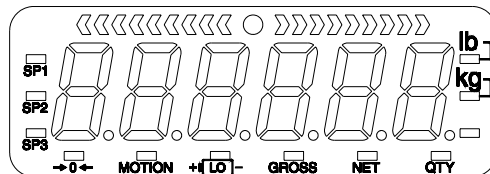

Figure 2: Model 350/355 LCD Display

ANNUNCIATORS

Annunciators provide mode and status information. When illuminated, they indicate the following conditions:

SP1	Setpoint #1 activated (relay 1 closed).
SP2	Setpoint #2 activated (relay 2 closed).
SP3	Setpoint #3 activated (relay 3 closed).
→0←	Displayed weight is at center-of-zero ($\pm \frac{1}{4}$ display graduation).
MOTION	Scale is in motion. Motion inhibited transmits and motion inhibited setpoint activation will be delayed until motion ceases.
GROSS	Displayed value represents the current gross weight.
NET	Displayed value represents the current net weight.
QTY	Displayed value represents the current piece quantity (Count).
lb	The displayed value is represented in pounds.
kg	The displayed value is represented in kilograms.
Oz, lb oz, g	The displayed value is represented in either ounces, pound ounces or grams.
+ Lo -	Illuminates when the battery reaches a low tolerance. LCD only

350 KEYPAD

The Model 350 offers a sealed 5-button elastomer keypad is used for operator input. Each key is assigned two distinct functions. Various key combinations are also used. Each key has secondary functions; allowing an operator to enter target values, perform piece samples, access setup parameters, etc.

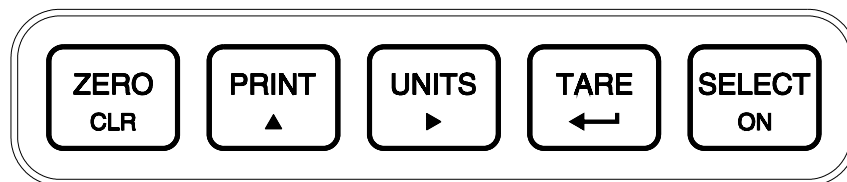

Figure 3: Model 350 Keypad

SECONDARY FUNCTIONS

The Model 350 keypad performs different functions in the Weigh Mode, the Setup Mode, and the Calibration Mode. Secondary functions for each key allow you to perform additional tasks.

Key Press	WEIGH MODE	Count Mode	Setup Mode
	Performs a gross zero function and/or clears an entry in progress. Hold this key on power-up to turn on the display regardless of P420.	Performs a quantity zero function and/or clears an entry in progress.	Exits the Setup Mode and/or answers "NO" to query prompts and/or clears an entry in progress.
	Performs a print function and/or 'scrolls' through digits during setpoint entry.	Performs a print function and/or 'scrolls' through digits during setpoint entry.	'Scrolls' through digits during data entry.
	Toggles between 'lb' and 'kg' and/or advances cursor to next entry position.	Toggles through standard sample sizes and/or begins a new sample entry.	Advances cursor to next entry position and/or cycles prompts.

Key Press	WEIGH MODE	Count Mode	Setup Mode
	Performs an auto-tare function (if enabled) and/or accepts an entry in progress.	Performs an auto-tare function and requests a piece sample and/or accepts an entry in progress.	Accepts an entry in progress and/or 'scrolls' through parameter sub-set selections and/or answers 'YES' to query prompts.
	Toggles between display modes and/or restores power to the indicator (if auto-shutoff enabled).	Toggles between display modes and/or restores power to the indicator (if auto-shutoff enabled).	Advances to the next setup parameter.
	Access Setup Mode.	Access Setup Mode.	No function.
	No function.	No function.	Return to the previous setup parameter.
	Absolute clear – clears an entry in progress and/or clears the value of a parameter.	No function.	Clears any entry in progress.
	Backspace – erases the right-most digit during data entry.	Backspace – erases the right-most digit during sample entry.	Backspace – erases right-most digit during data entry.
	Turn off indicator by holding key for approximately 1 second.	Turn off indicator by holding key for approximately 1 second.	Turn off indicator by holding key for approximately 1 second.
	Reverse character scroll during data entry.	Reverse character scroll during sample entry.	Reverse character scroll during data entry.

355 Keypad

The Model 355 keypad performs different functions in the Weigh Mode, the Setup Mode, and the Calibration Mode. The number keys make entering a tare value or average piece weight easier.

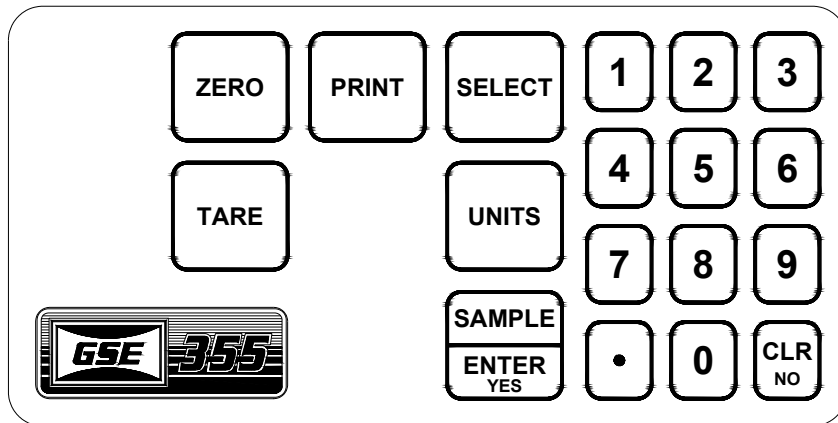









Figure 4: Model 355 Keypad

Key Press	WEIGH MODE	Count Mode	Setup Mode
	Performs a gross zero function and/or clears an entry in progress. Hold this key on power-up to turn on the display regardless of P420.	Performs a quantity zero function and/or clears an entry in progress.	Exits the Setup Mode and/or answers “NO” to query prompts and/or clears an entry in progress.
	Performs a print function and/or ‘scrolls’ through digits during setpoint entry.	Performs a print function and/or ‘scrolls’ through digits during setpoint entry.	‘Scrolls’ through digits during data entry.
	Toggles between ‘lb’ and ‘kg’ and/or advances cursor to next entry position.	Toggles through standard sample sizes and/or begins a new sample entry.	Advances cursor to next entry position and/or cycles prompts.
	Performs an auto-tare function (if enabled) and/or accepts an entry in progress. If the tare weight is known, key in the value and press  .	Performs an auto-tare function and requests a piece sample and/or accepts an entry in progress.	Accepts an entry in progress and/or ‘scrolls’ through parameter sub-set selections and/or answers ‘YES’ to query prompts.
	Toggles between display modes and/or restores power to the indicator (if auto-shutoff enabled).	Toggles between display modes and/or restores power to the indicator (if auto-shutoff enabled).	Advances to the next setup parameter.
	Performs a sample. If a number is keyed in before hand, it will be used as the sample size. Accepts an entry.	Performs a sample. If a number is keyed in before hand, it will be used as the sample size.	Accepts an entry.
	Clears an entry in progress. Hold this key on power-up to turn on the display regardless of P420.	Performs a quantity zero function and/or clears an entry in progress.	Exits the Setup Mode and/or answers “NO” to query prompts and/or clears an entry in progress.

Standard Functions

The Model 350 and 355 include built-in functions that you can enable through the Indicator Setup. for information on the setup and operation of the following standard functions:

- Check-weighing
- Fill, two-speed, single ingredient
- Batch, three ingredients, single-speed
- Loss-in weight, two-speed emptying
- Independent setpoints
- Parts counting
- Remote key operation
- Selectable, built-in data transmission formats
- Custom data transmissions

Weigh Mode Functions

The Model 350 and 355 keypads have five primary Weigh Mode functions:

 Performs a gross zero and selects the gross mode.

 Initiates data transmission out the communication port.

 Toggles the units of measure between lb, kg, g, lb oz, oz.

 Tares any displayed weight and selects the net mode.

 Toggles the display between GROSS, NET, QUANTITY and setpoint TARGETS (if enabled).

CHAPTER 2: INDICATOR INSTALLATION

This chapter contains information necessary for proper installation of the Model 350 and Model 355. Please review these instructions before installing your controller.

High voltages may exist within the enclosure. To prevent the risk of electrical shock, ALWAYS unplug the Model 350/355 when opening the enclosure. Installation and servicing of the Model 350/355 should be performed only by authorized and qualified service personnel.

For information on installing options, see *Chapter 3: Option Installation*. For NTEP and OIIML details, see *Chapter 6: Legal-for-Trade*.



IMPORTANT! The 350 Series indicators do not include an on/off switch and therefore must be installed near a power outlet socket that is easily accessible and in keeping with UL/CSA Safety Standards.

INFORMATION IMPORTANT! Prendre note que les contrôleurs de serie 350 ne sont pas munis d'interrupteurs "Marche / Arrêt". Par conséquent, il devront être installés près d'une source d'alimentation secteur accessible pour demeurer sous les exigences des normes de sécurité UL/CSA.

Mounting

The standard Model 350 zinc die cast enclosure is a NEMA1 (IP 20) equivalent. The Model 350/355 stainless steel enclosure meets NEMA 4X type specifications.

When choosing a mounting location for the Model 350 die cast, ensure that the unit is not installed in a washdown area or conductive dust environment.

DESKTOP MOUNTING

The standard enclosure is designed for desktop mounting. When set on a flat surface, the front face is angled for easy viewing. All wiring enters from the rear and can be secured with the included screw mounted cable ties.

PANEL MOUNTING

The optional panel mount kit allows the zinc die cast enclosure to be installed in a user panel. Allow for 2.00" (57.2mm) depth behind the panel surface. See *Panel Mount Kit* on page 16 for more details.

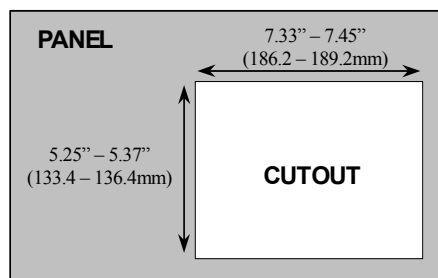

PERMANENT MOUNTING

The optional mounting bracket allows the zinc die cast enclosure to be securely fastened to another surface. The bracket is attached to the indicator with two thumbscrews and can be swiveled to an optimal viewing angle.

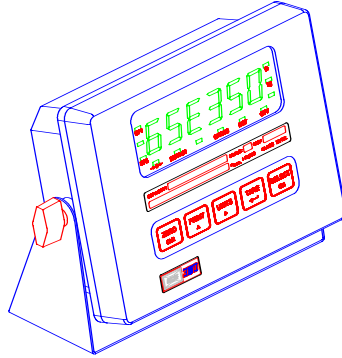

Figure 5: Model 350 Zinc Die Cast with Optional Mounting Bracket

OUTLINE DRAWINGS

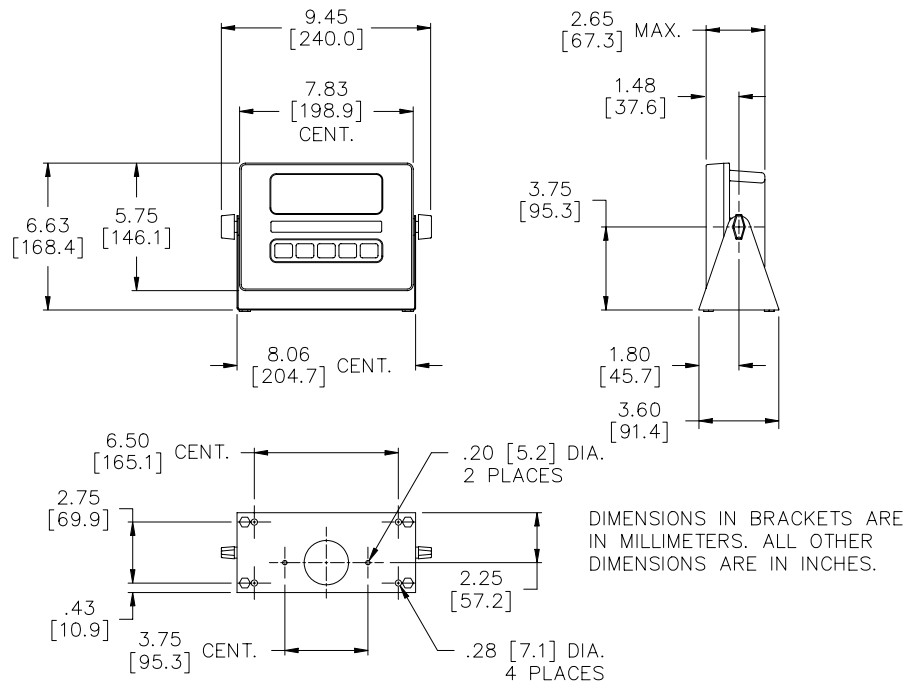

Figure 6: Model 350 Zinc Die Cast Front Dimensions

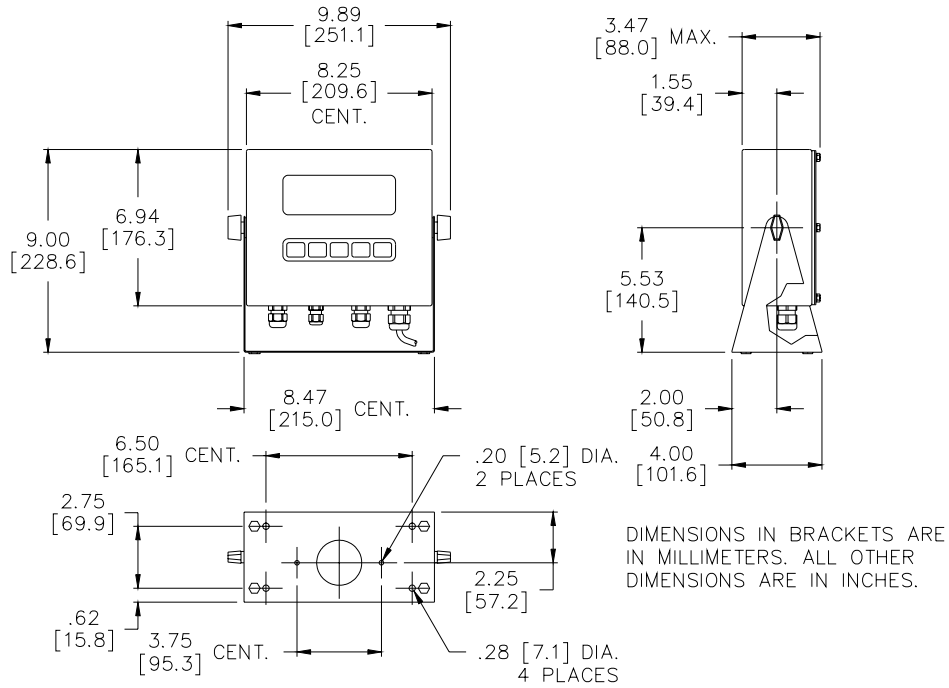

Figure 7: Model 350 Stainless Steel Dimensions

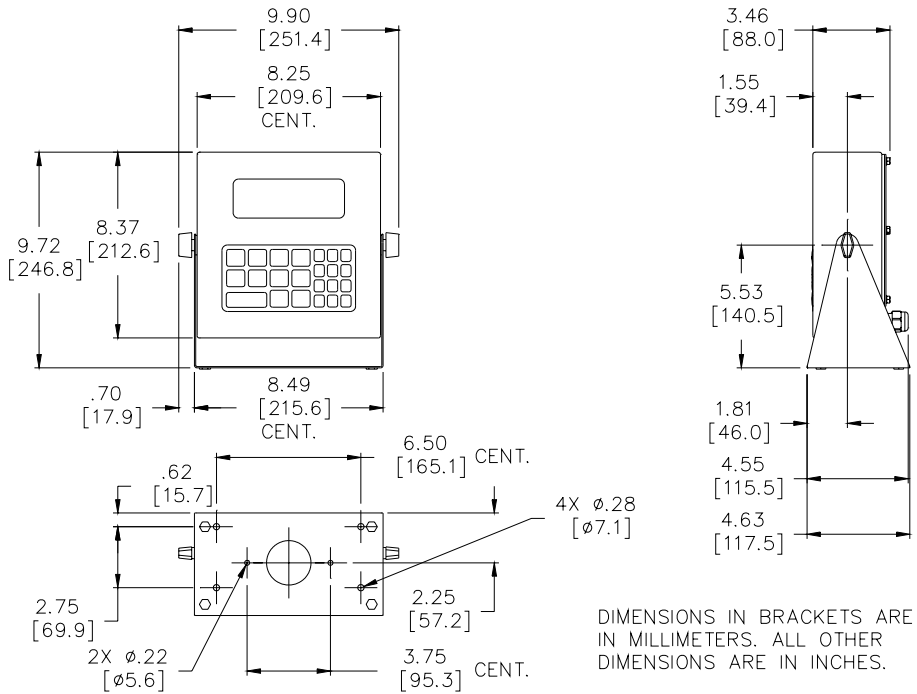

Figure 8: Model 355 Outline Drawing

Wiring

A description of all wiring terminals is included on the bottom label of the zinc die cast enclosure as shown in *Figure 9*.

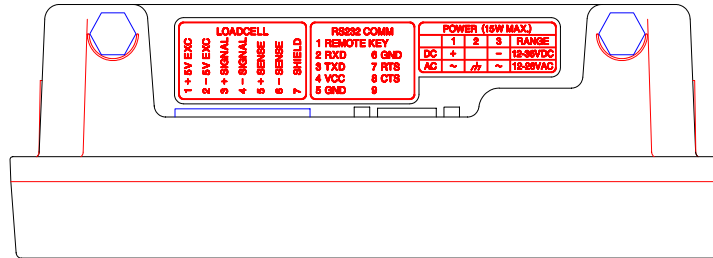

Figure 9: Model 350 Zinc Die Cast Enclosure Wiring Label

LOAD CELL CONNECTIONS

A high quality braided shield cable with 16 to 24 AWG stranded wire is recommended for load cell or summing box connections. Secure the cable by the cable tie on the die cast model, or route it through the strain relief supplied on the back of the internal power supply models (see *Figure 10*). Either four or six conductor cables can be used.



Do not tin the ends of the load cell wire! A terminal connection free from the effects of vibration and oxidation can be assured only if the load cell terminals securely grip a bare, stranded wire.

When using four conductor cables, (+ Excitation) must be connected together with (+ Sense), and (- Excitation) must be connected together with (- Sense) on the Model 350 die cast. Sense jumpers are standard on the Model 350 Stainless Steel (E3 and E4). Utilizing the (+) and (-) Sense leads of six conductor cables provides compensation for variations in the excitation voltage due to resistance changes in the cable.

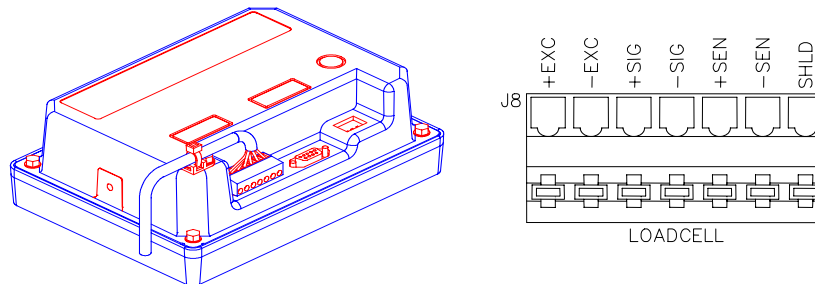

Figure 10: Cable Tie on Die Cast & Connector (J8) on Internal Power Supply Models



SERIAL PORT CONNECTIONS

Before connecting to the serial port, consideration should be given to the communication protocol and to any remote key requirements. For information on remote key operation, refer to *Remote Key Operation* on page 86. Use Table 1: Serial Port Connections to determine proper wiring to the communication port.

Communication connections are made through the DB9 male connector on the rear of the enclosure or a pigtailed cable through a strain relief (internal power supply model on J6 comm connection). The cable should be 20 to 28 AWG with a braided or foil shield for either model type. For maximum noise immunity on the die cast model, use a mating DB9 connector with a metal hood and a braided shield cable. Ensure that the braid makes good connection with the hood.

The maximum recommended cable length is 50 feet (15 meters). However, much longer connections are possible if using a properly shielded, low-capacitance cable.

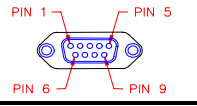
Table 1: Serial Port Connections

			Description	Label (Die cast encl. only)
1			REM	REMOTE KEY
2			RXD	Receive
3			TXD	Transmit
4			+5V	+5 VDC
5			GND	Digital Ground
6			GND	Digital Ground
7			RTS	Request-to-Send
8			CTS	Clear-to-Send
9			PI	Do Not Connect

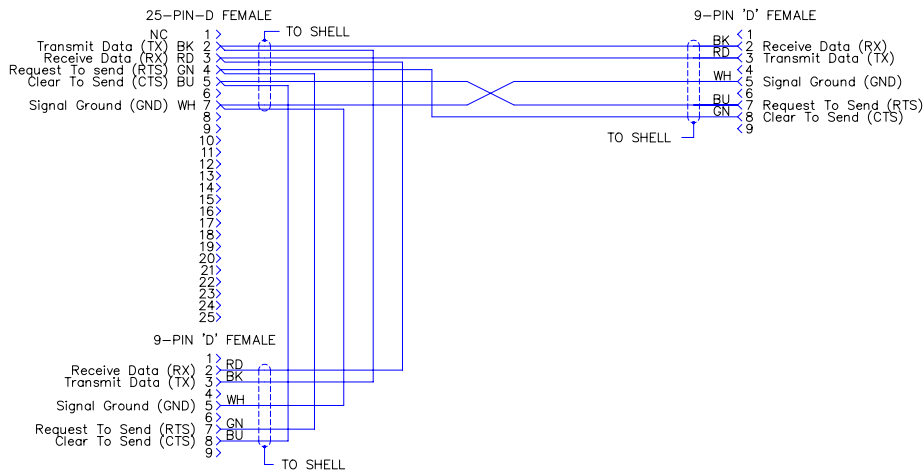

Figure 11: GSE Serial Cable, Part Number 22-30-29752

A communication cable (P/N: 22-30-29752) may be purchased from GSE for connection to a serial device having a DB25 or DB9 connector.

REMOTE KEY CONNECTION

A remote key may be connected to the Model 350/355 communication port to provide remote activation of print, tare, or zero functions.

The connection for the remote key input is between pin 1 and pin 6 of the DB9 communication port connector (see *Figure 12* for die cast, *Figure 13* for stainless). A two-conductor shielded cable between 28 and 20 AWG is recommended. The input requires a contact closure from a push-button switch, a ‘dry’ relay contact, a photo-eye, and a proximity sensor or other such device. A closure initiates the operation specified at P800.



Do not apply an external voltage to remote key terminals! Only a contact closure is required to activate the remote key input.

The open circuit voltage across the remote key pins is +5 VDC. A closed switch will conduct about 0.25 mA. Therefore, a low-voltage switch with gold-plated contacts is recommended. A Mercury-wetted switch will also work

well. A minimum contact duration of 100 ms is required. Once invoked, the selected remote key operation will not repeat until the contact is released and closed again.

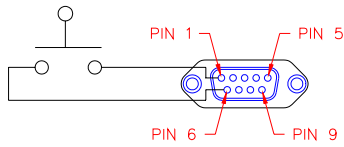

Figure 12: Remote Key Connection (Model 350 die cast)

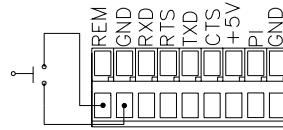

Figure 13: Remote Key Connection (Model 350 stainless and Model 355)

POWER CONNECTION

There are four ways to power the Model 350/355, with a 120 VAC wall mount transformer, with a 12-36VDC external source, with a 12-26VAC external source, or with the internal battery option.



The Model 350/355 does not include an on/off switch. In keeping with UL/CSA Safety Standards it must be installed near an easily accessible power outlet. Note that the **[ON]** key does not connect/disconnect the line voltage. It ‘awakens’ the Model 350/355 from a ‘sleep’ mode.

120VAC WALL MOUNT TRANSFORMER

An external wall mount transformer is supplied with the die cast Model 350 for connection to 120VAC, 60Hz power.



Do not cut the ground prong off the wall mount transformer!

To connect the transformer:

	Pin 1	Pin 2	Pin 3	Range
DC	+	N/C	-	12-36 VDC
AC	L	GND	N	12-26 VAC 50/60 HZ

1. Insert the polarized plug into the rectangular power connector.
2. Press the plug firmly into the hole to ensure it is seated properly.
3. Plug the wall mount transformer into a nearby wall outlet. Use only a three-wire grounded outlet.

EXTERNAL AC OR DC POWER SUPPLY

The Model 350/355 may be powered by an external 12-36 VDC or 12-26 VAC power source. The power supply should have a minimum current rating of 800mA with no options installed, a minimum current rating of 1.25A with options installed. Wire the plug as shown in *Figure 2-12*. Recommended plugs are AMP MTA .156” or MOLEX .156”.

External DC power supply cable GSE P/N 22-30-35459 plugs into the Model 350 die cast unit rear connector with bare wires on the other end.

POWER (15W MAX.)				
50/60HZ AC	1	2	3	RANGE
	~	⊕	~	12-26VAC
DC	+		-	12-36V

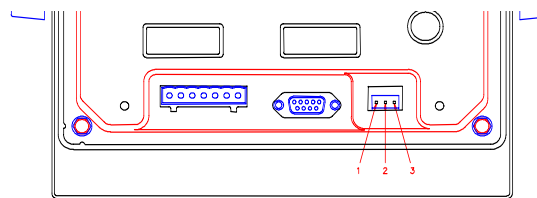

Figure 14: Model 350/355 Power Connections

INTERNAL AC OR DC POWER SUPPLY

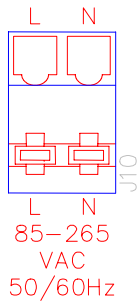
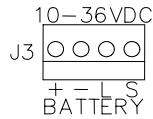

Figure 15: Model 350/355 Internal Power Supply Model AC Connections (J10)

The Model 350/355 internal power supply model may be powered by an external VAC power source connected to (J10) on the main board. Input power can be 85 – 265VAC, 0.5A; 50/60 Hz. See the internal AC power connector as shown in *Figure 15*. The *ground wire* is connected to a stud on the enclosure.

The Model 350/355 internal power supply model may be powered by an external 10-36 VDC power source connected to (J3) on the main board (also see *Battery Power Supply* on page 35). The power supply should have a minimum current rating of 800mA with no options installed, a minimum current rating of 1.25A with options installed.

Do not connect pins 3 or 4. The mating connector can be purchased from a local electronics supplier. Recommended connectors are GSE PN: 26-20-3365 (24 AWG) or GSE PN: 26-20-3366 (22 AWG) / AMP PN: 640441-3 (24 AWG) or AMP PN: 640440-3 (22 AWG). Connector cover GSE PN: 26-20-3389 or AMP PN: 643075-3.



	Pin 1	Pin 2	Pin 3	Pin 4	Range
DC	+	-	Low Batt	Shut Down	12-36 VDC

Figure 16: Model 350/355 Internal Power Supply Model DC Connections (J3)

CHAPTER 3: OPTION INSTALLATION

The capabilities of the Model 350 can be expanded with the use of one or more option kits. This chapter provides installation procedures for these options.

Model 350/355 Peripheral Options

The following options are available for the Model 350:

- **Swivel Bracket Kit** (die cast model) (GSE P/N 24350B-301C0)
Allows the indicator to be securely mounted to any surface.
- **Panel Mount Kit** (die cast model) (GSE P/N 24350B-300C0)
Allows the indicator to be easily mounted into existing cabinetry.
- **2 - Option Mounting Bracket** (GSE P/N 24350B-302C0)
Provides for mounting up to two option boards (required for the stainless steel enclosure only).
- **Analog Output Module** (GSE P/N 24350B-203B0)
Provides an electrically isolated, 16-bit analog signal for connectivity to external devices.
- **Setpoint Control Module** (GSE P/N 24350B-100C0) (USA)
(GSE P/N 24350B-100C1) (USA/Europe)
(GSE P/N 24350B-100C2)
Provides three discrete outputs for direct control of operation equipment.
- **Battery Power Supply** (die cast) (GSE P/N 24350B-120B0)
(stainless steel)(GSE P/N 24350B-121B0)
Gives the Model 350 portability.
- **Splash Guard** (GSE P/N 31-70-35578)
Adheres to the face of the stainless steel model for splash proof protection.
- **Transformer** (international version - IEC) (GSE P/N 20-20-35190)
Allows the Model 350 to run on overseas current.
- **20 mA Current Loop** (GSE P/N 24660B-404A0)
Provides a digital 20 mA current loop.

Swivel Bracket

The Model 350/355 has an optional stainless steel swivel bracket for secure mounting to desks, tabletops or walls. See the *Mounting* section beginning on page 8 for instructions on mounting the Model 350/355 using the swivel bracket.

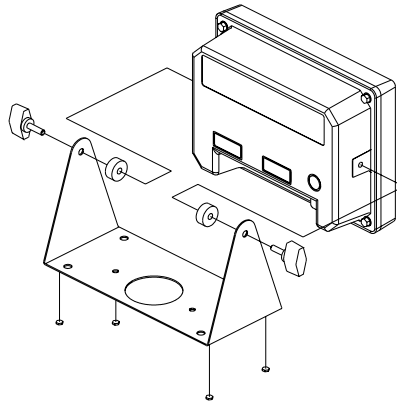

Figure 17: Swivel Bracket Installation (Die Cast Model)

To install the swivel bracket:

1. Unpack the Swivel Bracket option.
Be sure that all parts shown in *Figure 17* are accounted for.
2. Remove the two plastic Heyco plugs.
The plugs are located in the threaded bracket mounting holes on either side of the indicator. Be careful not to scratch the finish of the indicator when removing these plugs.
3. Place the two spacers against the bracket and then insert the thumb screws.
The spacer and bracket holes should align with the bracket mounting holes on either side of the enclosure.

Panel Mount Kit

The Panel Mount Kit provides an easy way to mount the indicator into new or existing cabinetry. See *Figure 18* for detailed instructions on panel mounting the Model 350/355. See also *NTEP Panel Mount Requirements* on page 101 for additional panel mounting NTEP requirements.

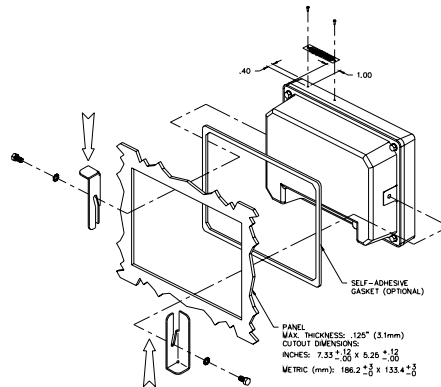

Figure 18: Model 350 Panel Mount Installation (Die Cast Model)

- INDICATOR CAN BE INSTALLED USING EITHER BUTTON OR HEX HEAD SCREWS. BOTH TYPES OF SCREWS ARE SUPPLIED WITH THE KIT.
- APPLY PRESSURE ON MOUNTING BRACKETS IN DIRECTIONS SHOWN. THIS WILL ENSURE THE INDICATOR IS DRAWN FIRMLY AGAINST THE PANEL.
- DRILL 1/16 (.0625) DIA. PILOT HOLES FOR PINS.
- ADD INDICATOR'S SERIAL NUMBER TO THE LABEL.

To install the Model 350 Panel Mount Kit:

1. Unpack the Panel Mount Kit.
Be sure that all parts shown in *Figure 18* are accounted for.
2. Remove the two plastic Heyco plugs.
The plugs are located in the threaded bracket mounting holes on either side of the indicator. Be careful not to scratch the finish of the indicator when removing these plugs.
3. Place the adhesive gasket around the panel cutout.
This step is optional. The gasket should be adhered onto the outside of the panel and centered around the cutout.
4. Place the Model 350 through the panel cutout.
This step may require a second person to hold the indicator in place. The indicator should be centered inside the cutout.
5. Using two small screws and star washers, attach the two panel mount brackets. The center holes of the brackets should align with the threaded bracket mounting holes on either side of the indicator. The two brackets should angle away from the indicator.
6. Using four long screws and four lock-nuts, secure the indicator to the panel. Thread the lock-nuts onto the screws so that they will not interfere with tightening the screws into the threaded bracket holes. Evenly tighten the four screws until they are snug. Do not over-tighten. Now thread the lock-nuts down until they are snug against the bracket.

Analog Card Connections

The 16-bit electrically-isolated analog output module provides a highly accurate analog signal, proportional to weight. This signal can be used for interfacing to PLCs, chart recorders, and other such devices.



See *Analog Output Setup* on page 23 for analog output software configuration details.



The Model 350/355 contains components which could be damaged by Electrostatic Discharge (ESD) if serviced improperly. Use proper ESD precautions (wear a wrist strap connected to ground, use grounded work stations, etc.) when opening the enclosure.

High voltages may exist within the enclosure! To prevent the risk of electrical shock, **ALWAYS** unplug the Model 350/355 when opening the enclosure. Installation and servicing of the Model 350/355 should be performed by authorized and qualified service personnel only.

Never connect or disconnect option board cables while the indicator is powered. Doing so may result in circuit board damage.

To install the Analog Output Module (350 die cast model):

1. Open the indicator. Remove the four screws from the back of the unit. It may help to remove the swivel bracket, if installed.
2. Place the back of the indicator, open side down, on a firm surface. Using a hammer and screwdriver, remove the appropriate knock-out.

It helps to place the screwdriver tip on the knockout pad, rather than in the groove. The knock-outs do not require much force to remove. If only installing one option, the left knock-out (as viewed from the rear) should be removed. A small file may be used to remove any burrs.

3. Flip the back cover over and place the Analog Output Module, component side down, over the four mounting holes. Install four 10mm screws to a minimum of 8 in/lb of torque.

Be sure the cable is already attached before installing the card. Also, be sure the cable is attached to the left-most connector (as viewed from the component side of the option board). The second connector is for ‘daisy-chaining’ another option card. The screws used to mount the option card are self-tapping and will require added torque when first installed.

4. Attach the loose end of the cable to the serial I/O connector (J7) on the main board or the open connector of a previously installed option card.

J7 is a 10-pin polarized connector. Be sure the cable is not twisted when installed. If this is a second option card, route the cable to the open connector of the first option card.

5. Reinstall the back cover. Tighten the four screws to a minimum of 8 in/lb torque.

Be sure to avoid ‘pinching’ the cable between the housing halves. Affix all appropriate labels to the back of the indicator.

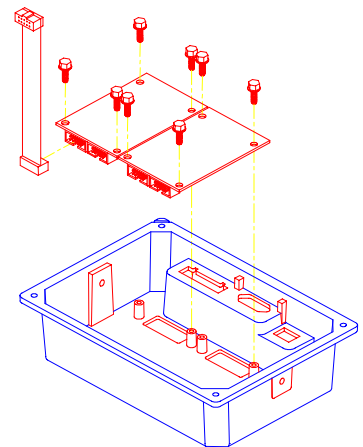

Figure 19: Option Board Installation (Die Cast Model 350)

To install the Analog Output Model (350 Stainless Model and 355):

1. Open the indicator.
Remove the eight screws from the back of the unit.
2. Locate the three studs and one thru-hole on the 350 main board that the option mounting bracket will be attached to. See Figure 20. Remove the nuts from the three studs on the main board.

It may help to position the option mounting bracket over the 350 main board to locate the three studs and one thru-hole.

3. Install the nylon stand-off supplied with the option bracket kit into the thru-hole on the option bracket. See *Figure 20*.

The thru-hole is located on the option bracket, towards the center of the board, on the irregular flanged section (a smaller hole than the others on the bracket) that would be positioned towards the power supply regulator (U11) with a flanged heat sink on it.

4. Install the three hex stand-offs onto the studs on the main board. Tighten the stand-offs gently with a 6 mm hex nut driver.
5. If this is the first option card, attach the loose end of the cable to the serial I/O connector (J7) on the main board. Let the card gently hang over to the outside of the enclosure until mounting. J7 is a 10-pin polarized connector.

This step is not necessary if this is the second card installed.

6. Position the nylon stand-off (attached to the bracket) into the hole on the main board while routing the threads of the other hex stand-offs thru the holes on the bracket, while pressing down over the nylon stand-off until it snaps into place.

Line-up the three other hex stand-offs into the bracket thru-holes first before securing the nylon stand-off into the main board thru-hole.

7. Secure the bracket into position with the hex nuts supplied with the kit. Do not over tighten.
8. Place one set (four pieces) of the nylon sleeve type stand-offs onto the four studs of the option bracket. Place the Analog Output Module, component side up, onto the nylon sleeve stand-offs. Install four hex nuts and secure gently.

Select the four studs closest to the (J7) connector of the main board to add the four sleeve stand-offs. Be sure the cable is already attached to (J7) on the main board before installing the card. Also be sure the cable is attached to the right-most connector (J3) (as viewed from the component side of the option board). The second connector (J1) is for 'daisy-chaining' another option card. The additional mounting hardware is supplied with the option bracket kit. This hardware should be saved for future use if not being used.

9. Route the analog cable through the available strain-relief.

Make sure to connect cable conductors to the proper terminals before closing the unit.

10. Reinstall the back cover. Tighten the eight screws securely to create a good seal.

Be sure to avoid 'pinching' the cable between the housing halves.

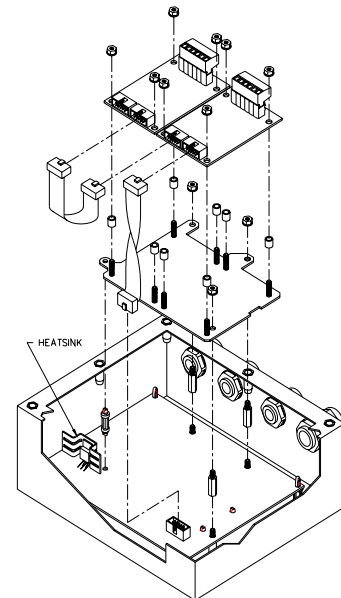
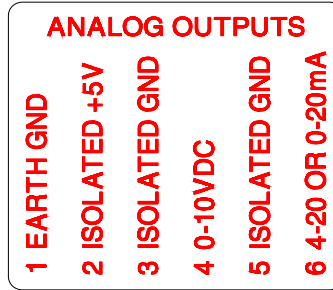

Figure 20: Option Board Installation (Stainless Model 350/355)

Table 2: Analog Output Connections

Pin	Connection Name	Description
1	Earth Ground	<i>Non-isolated</i> earth ground (future use).
2	+ 5 VDC	<i>Isolated</i> 5 volt source (future use).
3	Isolated Ground	Provides an <i>isolated</i> ground connection.
4	Vout	Used for the 0-10 VDC analog signal output.
5	Isolated Ground	Provides an <i>isolated</i> ground connection.
6	Iout	Used for 4-20 or 0-20 mA analog signal output.



Place this label on the rear of the indicator (die cast), above the analog option knockout.

(Stainless steel model) Cut off the text “ANALOG OUTPUTS” from the label and place it on the connector shown below (apply to the area just under the field external wire terminals).

Wire the option connector in accordance with the label (left to right).

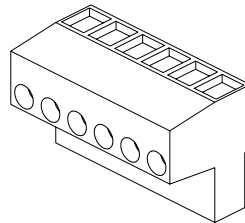

ANALOG BOARD DIAGNOSTIC AND TEST PROCEDURES



The following test procedures affect the analog output signal levels. Be sure to disconnect all peripheral devices attached to the analog option card.



Test equipment needed: precision DC voltmeter, 500 ohm precision resistor. The 500 ohm resistor must meet the following specifications: .01% tolerance and 5ppm temperature coefficient.



This test procedure requires that the initial analog option calibration procedure has been completed

To test the 0-10v output mode:

1. Enter the Setup Mode (see *Setup Mode* on page 40).
Chngs Poss!
P110.-- ~ F.S.= ~ 100.00
2. Attach the voltmeter + (red) lead to pin 3 (0-10VDC) and the - (black) lead to pin 2 (ISOLATED GND) of the Analog Output connector.
3. Key in .

Test ~ 0-10v
Per P176

4. Press or to set the output to 0%.
0-10v ~ 0P
0.00 VDC
5. Press or to increase the output to 25%.
0-10v ~ 25P
2.50 VDC
6. Press or to increase the output to 50%.
0-10v ~ 50P
5.00 VDC
7. Press or to increase the output to 75%.
0-10v ~ 75P
7.50 VDC
8. Press or to increase the output to 100%.
0-10v ~ 100P
1.00 VDC











To test the 0-20mA output mode:



Voltmeter readings are based on the use of a 500 ohm precision resistor. Caution! Do not exceed 500 ohms.

1. Enter the Setup Mode (see *Setup Mode* on page 40).
Chngs Poss!
P110.-- ~ F.S.= ~ 100.00
2. Attach the precision resistor to pin 5 and pin 6.
3. Attach the voltmeter + (red) lead to pin 6 (0-20 mA) of the analog output connector.
4. Attach the voltmeter - (black) lead to pin 5 (ISOLATED GND) of the Analog Output connector.
5. Key in (see *Setup Mode* on page 40).













Test ~ 0-20A
Per P176

6. Press  or  to set the output to 0%.
0-20A ~ 0P
 0.00 V
7. Press  or  to increase the output to 25%.
0-20A ~ 25P
 2.5 V
8. Press  or  to increase the output to 50%.
0-20A ~ 50P
 5 V
9. Press  or  to increase the output to 75%.
0-20A ~ 75P
 7.5 V
10. Press  or  to increase the output to 100%.
0-20A ~ 100P
 10 V



To test the 4-20mA output mode:



Voltmeter readings are based on the use of a 500 ohm precision resistor.
 Caution! Do not exceed 500 ohms.



1. Enter the Setup Mode (see *Setup Mode* on page 40).
Chngs Poss!
P110.-- ~ F.S.= ~ 100.00
2. Attach the precision resistor to pin 5 and pin 6.
3. Attach the voltmeter + (red) lead to pin 6 (4-20 mA) of the analog output connector.
4. Attach the voltmeter - (black) lead to pin 5 (ISOLATED GND) of the Analog Output connector.
5. Key in   (see *Setup Mode* on page 40).
Test ~ 4-20A
 Per P176
6. Press  or  to set the output to 0%.
4-20A ~ 0P
 2 V
7. Press  or  to increase the output to 25%.
4-20A ~ 25P
 4 V
8. Press  or  to increase the output to 50%.
4-20A ~ 50P

6 V

9. Press  or  to increase the output to 75%.

4-20A ~ 75P

8 V

10. Press  or  to increase the output to 100%.

4-20A ~ 100P

10V

Analog Output Setup

Table 3: Analog Output Parameters

Parameter Setting	Displayed Name	Description	Type/choices (*=Default)
P171.00	<i>AnAlg</i>	Enable analog option.	Disbl*, Enabl
P172.00	<i>AnPar</i>	Parameter that analog signal corresponds to. <i>Displayed</i> corresponds to gross while viewing the gross weight and net otherwise.	Gross*, Net, Displayed
P173.--	<i>AnlFS</i>	Full scale value at which P172 selection yields an output of 10 volts. If set to 0, uses P110 setting.	Numeric Entry: 0* to ±1,000,000
P174.--	<i>AnOff</i>	Offset value which yields a 0 volt output.	Numeric Entry: 0* to ±1,000,000
P175.10	<i>AnRng</i>	Range Value (1-10) which specifies the max value of analog output – entered in terms of voltage. NOTE: This does not change the analog span. A 0-10,000 lb. output set to 8 will stop increasing its analog signal at 8,000 lbs.	Numeric entry: 0 to 10*
P176.01	<i>AnRst</i>	Reset state – Specifies analog signal level when Model 350 and Model 355 enters Setup Mode.	10 V (Max Output) 0 V (Min Output) No Change*
P177.00	<i>AType</i>	Specifies output type: voltage or current.	0 –10 volts*, 0 -20mA, 4 -20mA

$$V_{\text{out}} = \left(\frac{(\text{P172: Parm Value}) - (\text{P174: Zero Offset})}{(\text{P173: Full Scale Value}) - (\text{P174: Zero Offset})} \right) * 10$$

The actual output signal is calculated as follows:

If the result is greater than the Max Range Value (P175), then the analog signal is limited to the Max Range Value.

Analog Output Calibration

Table 4: Analog Output Calibration Parameters

PARAMETER SETTING	DISPLAYED NAME	DESCRIPTION	TYPE/CHOICES (*=DEFAULT)
P61200	10oFF	Value required to precisely output 0V in 0 – 10V output mode (i.e. offset).	Numeric Entry: 0 to 15,000 2,923*
P61201	10Gn	Value required to precisely output 10V in 0 – 10V output mode (i.e. gain).	Numeric Entry: 50,000 to 65,535 61,027*
P61202	0oFF	Value required to precisely output 0 mA in 0 – 20 mA output mode (i.e. offset).	Not adjustable: 0*
P61203	0Gn	Value required to precisely output 20 mA in 0 – 20mA output mode (i.e. gain).	Numeric Entry: 50,000 to 65,535 54,555*
P61204	4oFF	Value required to precisely output 0 mA in 4 – 20 mA output mode (i.e. offset).	Numeric Entry: 0 to 15,000 10,910*
P61205	4Gn	Value required to precisely output 20 mA in 4 – 20mA output mode (i.e. gain).	Numeric Entry: 50,000 to 65,535 54,555*
P61206	Srln	Analog option board serial number.	Numeric Entry: 0* - 4,294,967,295

The analog output calibration procedure establishes explicit zero and full scale values for each of the three analog output modes: 0 – 10V, 0 – 20 mA and 4- 20 mA. There are five adjustment values for the analog option, located at the information parameters P61200 through P61205, that allow the zero and full scale output of each mode to be adjusted to exact values. This allows the analog option to be configured to match the needs of the system being connected to its outputs.

The calibration values for each of these modes has been determined at the factory. These values are provided on paper with each board to make calibrating the analog option a simple process. Each analog option board can be identified by its serial number, which is entered in the unit during the calibration process.

ENTERING ANALOG CALIBRATION VALUES

An example of the printout included with each analog option kit follows below:

```

100%s23640%e           Access Setup Modes, Allowing Changes

60100%s%e             P60100.  c1998-GSE-
60101%s%e             P60101.  0Model 350  350p01009
60102%s%e             P60102.  06-30-2000

60200%s%e             P60200.  BrdSn573192
60201%s%e             P60201.  AuditTrail Euro  00001
60202%s%e             P60202.  InsSn329074
60203%s%e             P60203.  AuditTrail Cal.  00025
60204%s%e             P60204.  AuditTrail Setup 00050



61200%s2923%e         P61200.  10off  2923
61201%s61027%e        P61201.  10 Gn  61027
61202%s0%c            P61202.  0 off  0
    
```





```

61203%s54555%e      P61203.  0  Gn  54555
61204%s10910%e      P61204.  4  off 10910
61205%s54555%e      P61205.  4  Gn  54555
61206%s123456%e     P61206.  Srl n 123456

```

```
%z                      Exit Setup Mode
```

Analog calibration values can be entered into the Model 350 and Model 355 by keying in the data in the left-hand column, beginning at the line starting with “61200...”, replacing the “%s” character pairs with the  key and “%e” with the  (350) or  (355) key. The line with the “%c” is not adjustable and cannot be entered.

You can adjust the included factory recommended offset and gain values to precisely configure the system being connected to these outputs. Once the initial factory values have been entered, pressing the  (350) or  (355) key will cause the count value to increase one count, and pressing the  +  keys will decrement the count value by one count. All changes made are updated “live” to aid in calibrating a specific device to the analog option board output. Holding down the key(s) will repeat the increment/decrement action.

ANALOG OUTPUT EXAMPLE

Analog Parameter Setting	Parameter Description	Example Value	Comments
P172.01	Net Weight	3.00 lb	Current net weight.
P173.--	Analog Full Scale	20	Net weight value that would give maximum analog output.
P174.--	Zero Offset	-40	Net weight value that would give minimum analog output.
P175.--	Max Range Value	8	Maximum analog output allowed (entered in terms of voltage).

$$V_{\text{out}} = \left(\frac{3 - (-40)}{20 - (-40)} \right) * 10 = \left(\frac{43}{60} \right) * 10 = 7.166$$

Since 7.166 v is less than 8 v (per P175), the output signal is not restricted and would be 7.166 v.

If a current output is selected, the output is a milli-amp current where 0 volts corresponds to either 0 mA or 4 mA (as per P177) and 10 volts would translate to 20 mA. Values in between would be scaled proportionately:

$$I_{\text{out}} = \left(\frac{(20 \text{ mA} - 4 \text{ mA}) * 7.166 \text{ v}}{10 \text{ v}} \right) + 4 \text{ mA} = \left(\frac{16 * 7.166}{10} \right) + 4 = 15.465 \text{ mA}$$

Analog signal resolution: the output is the result of a 16 bit conversion resulting in a resolution of 1 part in 65535 or 10 / 65535 = 0.00015 v.

Setpoint Card Connections

Using one of the software setpoint configurations (see *General Setpoint Setup* on page 63) in conjunction with the setpoint option board gives the Model 350/355 the ability to directly control external devices such as valves, relays, actuators, etc.

There are up to three setpoint outputs available. The activation and deactivation is controlled by the setpoint configuration. The outputs are capable of driving up to one Amp at 20-280VAC & 2 Amp at 3-60VDC. The solid state relays are normally open (NO) contacts.



See *General Setpoint Setup* on page 63 for setpoint software configuration details.



The Model 350/355 contains components which could be damaged by Electrostatic Discharge (ESD) if serviced improperly. Use proper ESD precautions (wear a wrist strap connected to ground, use grounded work stations, etc.) when opening the enclosure.

High voltages may exist within the enclosure! To prevent the risk of electrical shock, **ALWAYS** unplug the Model 350/355 when opening the enclosure. Installation and servicing of the Model 350/355 should be performed by authorized and qualified service personnel only.

Never connect or disconnect option board cables while the indicator is powered. Doing so may result in circuit board damage.

To install the Setpoint Control Module (350 die cast):

1. Open the indicator.
Remove the four screws from the back of the unit. It may help to remove the swivel bracket, if installed.
2. Place the back of the indicator, open side down, on a firm surface. Using a hammer and screwdriver, remove the appropriate knock-out.
It helps to place the screwdriver tip on the knockout pad, rather than in the groove. The knock-outs do not require much force to remove. If only installing one option, the left knock-out (as viewed from the rear) should be removed. A small file may be used to remove any burrs.
3. Flip the back cover over and place the Setpoint Control Module, component side down, over the four mounting holes. Install four 10mm screws to a minimum of 8 in/lb of torque.
Be sure the cable is already attached before installing the card. Also be sure the cable is attached to the left-most connector (as viewed from the component side of the option board). The second connector is for 'daisy-chaining' another option card. The screws used to mount the option card are self-tapping and will require added torque when first installed.
4. Attach the loose end of the cable to the serial I/O connector (J7) on the main board or the open connector of a previously installed option card.
J7 is a 10-pin polarized connector. Be sure the cable is not twisted when installed. If this is a second option card, route the cable to the open connector of the first option card.
5. Reinstall the back cover. Tighten the four screws to a minimum of 8 in/lb torque.

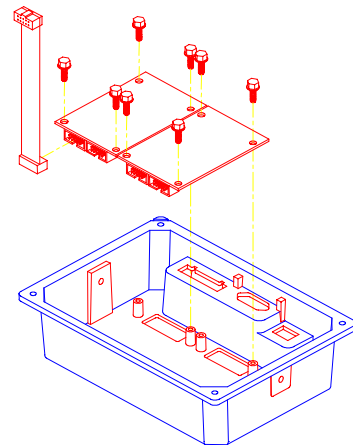

Figure 21: Option Board Installation (Die Cast Model 350)

Be sure to avoid ‘pinching’ the cable between the housing halves. Affix all appropriate labels to the back of the indicator.

To install the Setpoint Control Model (350 Stainless and 355):

1. Open the indicator.
Remove the eight screws from the back of the unit.
2. Locate the three studs and one thru-hole on the main board that the option mounting bracket will be attached to. See *Figure 22*. Remove the nuts from the three studs on the main board.
It may help to position the option mounting bracket over the 350 main board to locate the three studs and one thru-hole.
3. Install the nylon stand-off supplied with the option bracket kit into the thru-hole on the option bracket. See *Figure 22*.
The thru-hole is located on the option bracket, towards the center of the board, on the irregular flanged section (a smaller hole than the others on the bracket) that would be positioned towards the power supply regulator (U11) with a flanged heat sink on it.
4. Install the three hex stand-offs onto the studs on the main board.
Tighten the stand-offs gently with a 6 mm hex nut driver.
5. If this is the first option card, attach the loose end of the cable to the serial I/O connector (J7) on the main board. Let the card gently hang over to the outside of the enclosure until mounting. J7 is a 10-pin polarized connector.
This step is not necessary if this is the second card installed.
6. Position the nylon stand-off (attached to the bracket) into the hole on the main board while routing the threads of the other hex stand-offs through the holes on the bracket, while pressing down over the nylon stand-off until it snaps into place.
Line-up the three other hex stand-offs into the bracket thru-holes first before securing the nylon stand-off into the main board thru-hole.
7. Secure the bracket into position with the hex nuts supplied with the kit. Do not over tighten.
8. Place one set (four pieces) of the nylon sleeve type stand-offs onto the four studs of the option bracket. Place the Setpoint Control Module, component side up, onto the nylon sleeve stand-offs. Install four hex nuts and secure gently.

Select the four studs closest to the (J7) connector of the main board to add the four sleeve stand-offs. Be sure the cable is already attached to

(J7) on the main board before installing the card. Also be sure the cable is attached to the right-most connector (J3) (as viewed from the component side of the option board). The second connector (J1) is for ‘daisy-chaining’ another option card. The additional mounting hardware is supplied with the option bracket kit. This hardware should be saved for future use if not being used.

9. Route the analog cable through the available strain-relief. Make sure to connect cable conductors to the proper terminals before closing the unit.
10. Reinstall the back cover. Tighten the eight screws securely to create a good seal. Be sure to avoid ‘pinching’ the cable between the housing halves.

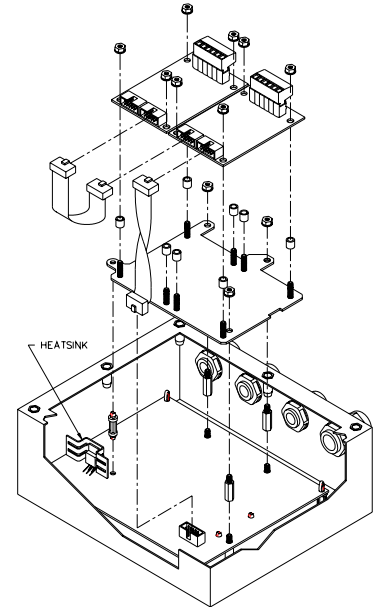

Figure 22: Option Board Installation (Stainless Model 350/355)

Table 5: Setpoint Output Specifications (24350B-100C0)

Characteristic	Limits
Operating Voltage Range (47-63 Hz)	20-280 VRMS
Max Load Current	1 Amp RMS
Min Load Current	0.5 mA RMS
Min. Off-State Impedance	80K Ohms
Max Surge Current	24 Amp peak

Table 6: Setpoint Control Connections (24350B-100C0)

Pin	Connection Name	Description
1	Line 1	Line voltage in for setpoint 1.
2	Load 1	Voltage out for setpoint 1.
3	Line 2	Line voltage in for setpoint 2.
4	Load 2	Voltage out for setpoint 2.
5	Line 3	Line voltage in for setpoint 3.
6	Load 3	Voltage out for setpoint 3.

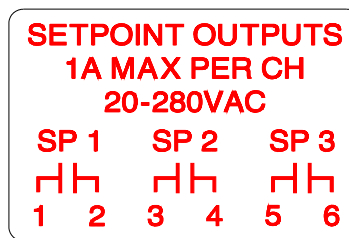

Place this label above the setpoint card knockout (die cast).

(Stainless steel model) Cut off the text "SETPOINT OUTPUTS" from the label and place it on the connector shown in Figure 23 (apply to the area just under the field external wire terminals).

Table 7: Setpoint Output Specifications (24350B-100C1)

Characteristic	Limits
Operating Voltage Range (20-500 Hz)	20-280 VRMS
Max Load Current	1 Amp RMS
Min Load Current	5 mA RMS
Min. Off-State Impedance	220K Ohms
Max Surge Current	20 Amp peak

Table 8: Setpoint Control Connections (24350B-100C1)

Pin	Connection Name	Description
1	Line 1	Line voltage in for setpoint 1.
2	Load 1	Voltage out for setpoint 1.
3	Line 2	Line voltage in for setpoint 2.
4	Load 2	Voltage out for setpoint 2.
5	Line 3	Line voltage in for setpoint 3.
6	Load 3	Voltage out for setpoint 3.

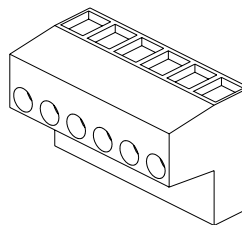
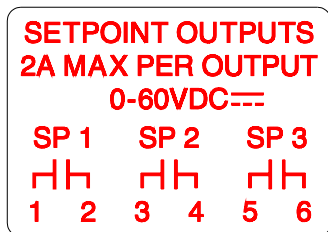

Place this label above the setpoint card knockout (die cast)

Figure 23: Wire the option connector in accordance with the label (left to right)

(Stainless steel model) Cut off the text “SETPOINT OUTPUTS” from the label and place it on the connector shown in Figure 23 (apply to the area just under the field external wire terminals).

SETPOINT BOARD DIAGNOSTIC AND TEST PROCEDURES



This test procedure affects the setpoint output. Be sure to disconnect all peripheral devices attached to the setpoint option card.



Test Equipment needed: Load device with power source.

To test the setpoint option card:

1. Enter the Setup Mode (see *Setup Mode* on page 40).

Chngs Poss!

P110.-- ~ F.S.= ~ 100.00

2. Key in .

Test ~ Setpt

Load Device Inactive

3. Attach the load and power source in series with Setpoint 1 contacts.

4. Press or to activate only output #1.

Test ~ Spt 1

Load Device Active

5. Attach the load and power source in series with Setpoint 2 contacts.

6. Press or to activate only output #2.

Test ~ Spt 2

Load Device Active

7. Attach the load and power source in series with Setpoint 3 contacts.

8. Press or to activate only output #3.

Test ~ Spt 3

Load Device Active

RS-485 Networking

The Model 350/355 controller supports address recognition for multi-drop communications. This section describes the installation of the RS-485 network option. Firmware revision 450350-01013 or later is required for RS-485 operation. For setup and operation information, see page 86.



The Model 350/355 contains components which could be damaged by Electrostatic Discharge (ESD) if serviced improperly. Use proper ESD precautions (wear a wrist strap connected to ground, use grounded work stations, etc.) when opening the enclosure.

High voltages may exist within the enclosure! To prevent the risk of electrical shock, **ALWAYS** unplug the Model 350/355 when opening the enclosure. Installation and servicing of the Model 350/355 should be performed by authorized and qualified service personnel only.

Never connect or disconnect option board cables while the indicator is powered. Doing so may result in circuit board damage.

To install the RS-485 Network Option (350 die cast):

1. Open the indicator.
Remove the four screws from the back of the unit. It may help to remove the swivel bracket, if installed.
Remove the rear cover.
2. Remove the U6 IC from its socket.
3. Remove the white wire jumper.
4. Snap the plastic spacers into the three mounting holes.
5. Gently press the option board into the socket.
6. Reinstall the back cover. Tighten the screws to at least 8 in/lb torque.
7. Place the included sticker over the rear connector sticker RS232.

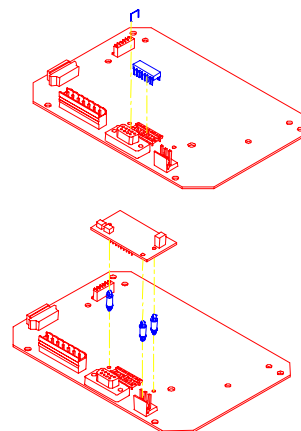

Figure 24: RS-485 Installation (Die Cast 350)

To install the RS-485 Network Options (350 Stainless and 355):

1. Open the indicator.
Remove the eight screws from the back of the unit and remove the cover.
2. Apply the included sticker to the J6 comm port. The label will go over the silk screen on the board.
3. Remove the U6 IC from its socket.
4. Remove the white wire jumper.
5. Snap the plastic spacers into the three mounting holes.
6. Gently press the option board into the socket.
7. Reinstall the back cover. Tighten the eight screws securely to create a good seal.

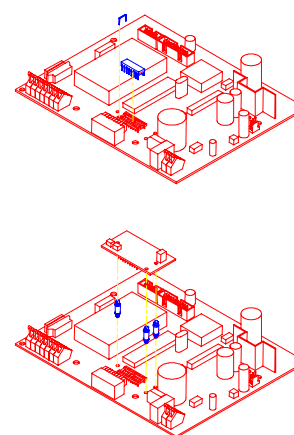

Figure 25: RS-485 Installation (Stainless 350/355)

NETWORK CONNECTIONS

Apply the supplied label over the appropriate COMM PORT pin designations.

On the stainless steel enclosure, apply the label marked *Model 350/355 SS* to the main board (J6). Position the label so the **REM** (remote) on the main board is covered with the **REM** (remote) of the supplied label. The new label will redefine all of the other pin designations.

On the die cast enclosure, apply the label marked *Model 350 STD* to the outside of the enclosure. The supplied label **RS485 COMM** should completely cover the **RS232 COMM** portion of the factory installed label.

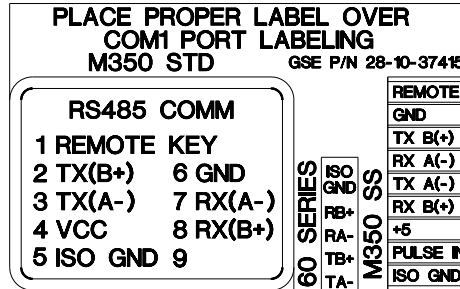

Place this label over the COMM PORT pin designations.

HALF DUPLEX (2-WIRE)

Installing jumpers 1, 2 and 4 on the RS-485 option board electrically connects pin RX B(+) to pin TX B(+), and pin RX A(-) to pin TX A(-) on the option board. This effectively provides two + and two - pin connections, enabling easy connection of network lines in parallel from device to device without having to position two wires into the same lever socket. A B(+) line from each device on the network should be connected in parallel to the next device on the network. This is also true for all A(-) lines.

The units inside the two end-points of the network loop will utilize both A(-) pin connections and both B(+) pin connections. The units at the end-points of the network will utilize only one A(-) pin connection and one B (+) pin connection.

FULL DUPLEX (4-WIRE)

Removing jumpers 1, 2 and 4 on the RS-485 option board requires that the transmit and receive lines be wired independently of one another. The RX B(+) and RX A(-) receive lines must be wired in parallel to the next device's RX B(+) and RX A(-) receive lines, and the TX B(+) and TX A(-) transmit lines must be wired in parallel to the next device's TX B(+) and TX A(-) transmit lines.

In order to connect network lines in parallel from device to device it is necessary to position two wires into the same lever socket. This requires that the wire used to build the network be 24 AWG or smaller to allow both wires to fit into the same lever socket.

BOTH HALF DUPLEX AND FULL DUPLEX

The network boards on *both* end-points should install jumper 3 on the RS-485 option board to engage the 120 Ω termination resistor (R8). The boards between the two end-points should remove jumper 3 on the RS-485 option board.

The isolated ground (ISO GND) should be connected in parallel from unit to unit. A shielded twisted two pair cable is recommended throughout the network.

Half Duplex

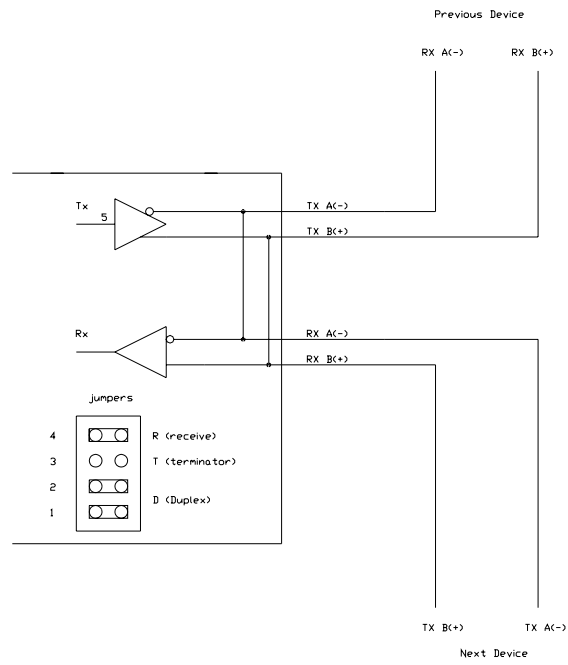

Full Duplex

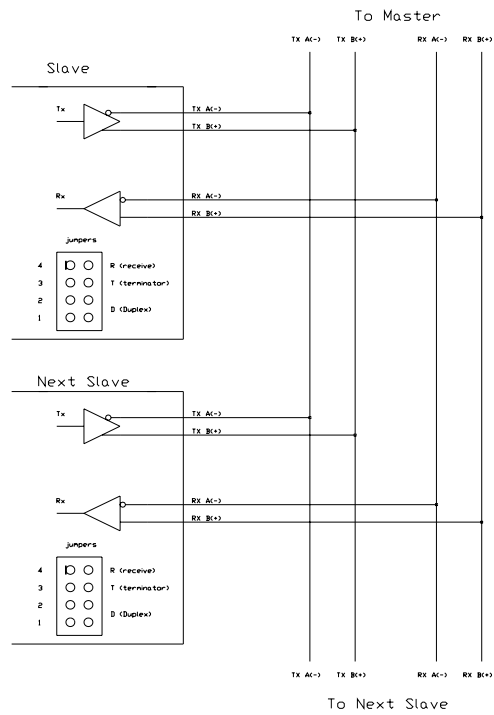

20 mA Current Loop Option

Description: This option will convert the comm port of the indicator to a 20 mA current loop instead of an RS-232. This is a digital communication signal and should not be confused with a 4 to 20-mA (or 0-20 mA) which are analog output signals. The intended use is primarily printers and scoreboard displays.

Mounting/Installation: This option will mount into the socket for the comm port RS-232 chip on the main board. This option will exclude the use of the RS-485 option board. (I.e. only the RS-485 OR the 20 mA option can be installed into an indicator). Three snap-in stand-offs are included with the board to secure it to the main board beneath it.

INSTALLATION:

1. Open the indicator and gain access to the main board.
2. Remove the RS232 IC from its socket. (See table for location)
3. Remove the white wire jumper. (See table for location)
4. Snap the plastic spacers into the three mounting holes.
5. Gently press the option board into the socket.
6. Apply the proper portion of the included sticker to the COMM port. The label will either go over the silk screen on the board or on the rear cover. (See table for location)
7. Reassemble the indicator.

Location of Components to Remove		
	350 Die cast	350 SS/355
RS232 IC	U6	U6
Jumper	E2	E2
Label Location	Rear Cover	J6

BI-DIRECTIONAL

Both the transmit output and the receive input of the indicator are available as 20 mA signals. None of the handshake signals are supported for the 20-mA current loop operation.

BAUD

Only baud rates of 9600 baud and less are supported.

ACTIVE/PASSIVE

The Tx output may be used as an active or passive output from the indicator. Either active or passive is chosen depending upon which terminals are used for the connections. In active mode the indicator supplies the current. In passive mode, the external device supplies the current. The Rx input is available in passive mode only.

ISOLATION

The input and output are electrically isolated from the main board as well as earth ground and each other, for both passive and active modes of operation. Isolation is a minimum of 1000v.

MAX VOLTAGE

Active mode Tx current loop provides a driving voltage of 12v. This will allow 20 mA current flow with up to a 600 ohm load. Passive mode will work with an external driving voltage of up to 50v.

CONNECTIONS

The field connections to the 20 mA circuitry will be made at the main board's comm connector, i.e. the lever connector on the '60-Series' products and the Model 350/355 Stainless Steel version and at the 'D' connector on the Model 350 Zinc Die Cast unit. A 3-part label is supplied with the option to re-label the connections on the main circuit board. The appropriate part of this label should be applied over the existing comm port markings on that indicator. Below is a copy of the label drawing.

CABLE

The length for the current loop is 1000 ft. maximum. This is for the entire loop, not from device to device. Example: 1 transmitter and 1 receiver can have a maximum of 500 ft. of 2 conductor cable between them.

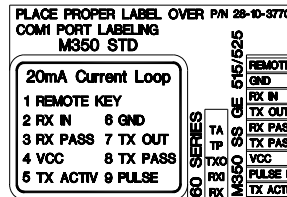

Place this label over the COMM PORT pin designations.

Table 9: 20 mA Label Terminology

TRANSMITTER CONNECTIONS			
Indicator	Transmitter Output	Transmit current input, Active	Transmit current input, Passive
350 SS & ZDC	TX OUT	TX ACTIV	TX PASS
RECEIVER CONNECTIONS			
Indicator	Receiver current output		Receiver current input
350 SS & ZDC	RX PASS		RX IN

CONNECTED DEVICES

While 20 mA current loops can allow for more than one transmitter and/or receiver, the indicator and/or option board do not include any address recognition or collision avoidance and/or detection to promote this usage. If the 20-mA loop is intended to be used in this manner, proper planning for these issues is required.

Table 10: Connecting to External Devices

Typical Installations			
Model 350/355		External Device	
Passive 20 mA Output	TP	RX+	Active 20 mA Input
	TXO	RX-	
Passive 20 mA Input	RXI	RX+	Active 20 mA Output
	RX	RX-	
Active 20 mA Output	TXO	RX+	Passive 20 mA Input
	TA	RX-	

Battery Power Supply

The Battery Module gives the Model 350/355 portability, providing an Model 350/355 with an LCD display and one loadcell 20 hours minimum battery life, or an Model 350/355 with an LED display and one loadcell 8 hours minimum battery life.

This section covers the battery connections on the Model 350/355 main board, the installation of the battery option board, and the battery

MOUNTING

The circuit board and battery fit inside the die cast and stainless steel enclosures. The circuit board acts as the hold down for the battery in both enclosures. Please refer to *Figure 26* for installation diagram for the Model 350/355 Stainless Steel Enclosure, or for installation diagram for the Model 350 Die Cast Enclosure.



Installing the battery option prevents installation of analog or setpoint options.



Review the connection diagrams thoroughly before installing the cable that connects the Model 350/355 main board to the option board. **DAMAGE TO THE OPTION BOARD OR INDICATOR CAN RESULT FROM IMPROPER INSTALLATION.**

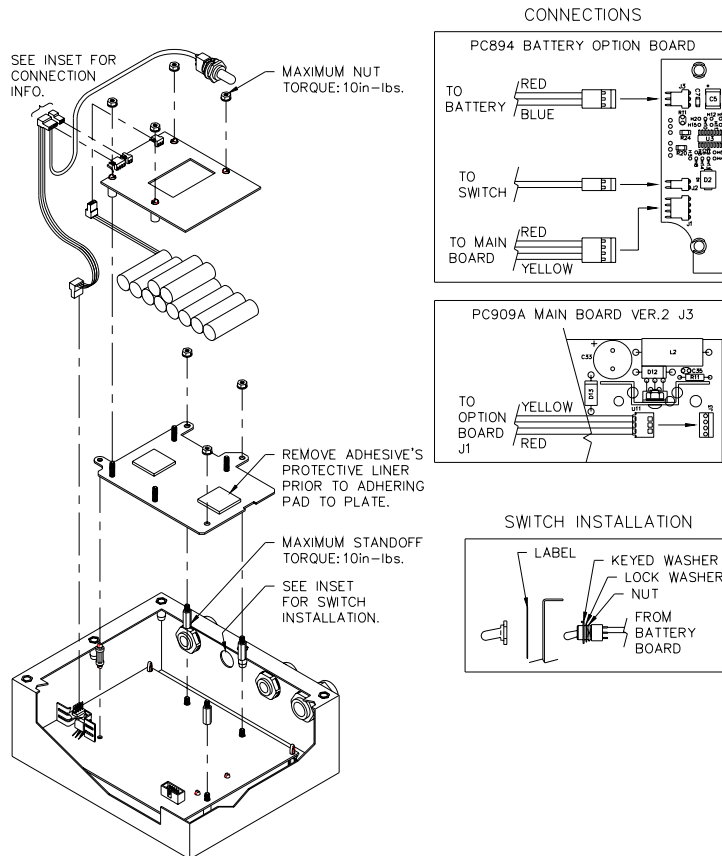

Figure 26: Battery Option Installation (350 Stainless Steel and 355)

DISCONNECT POWER BEFORE INSTALLING OPTION.

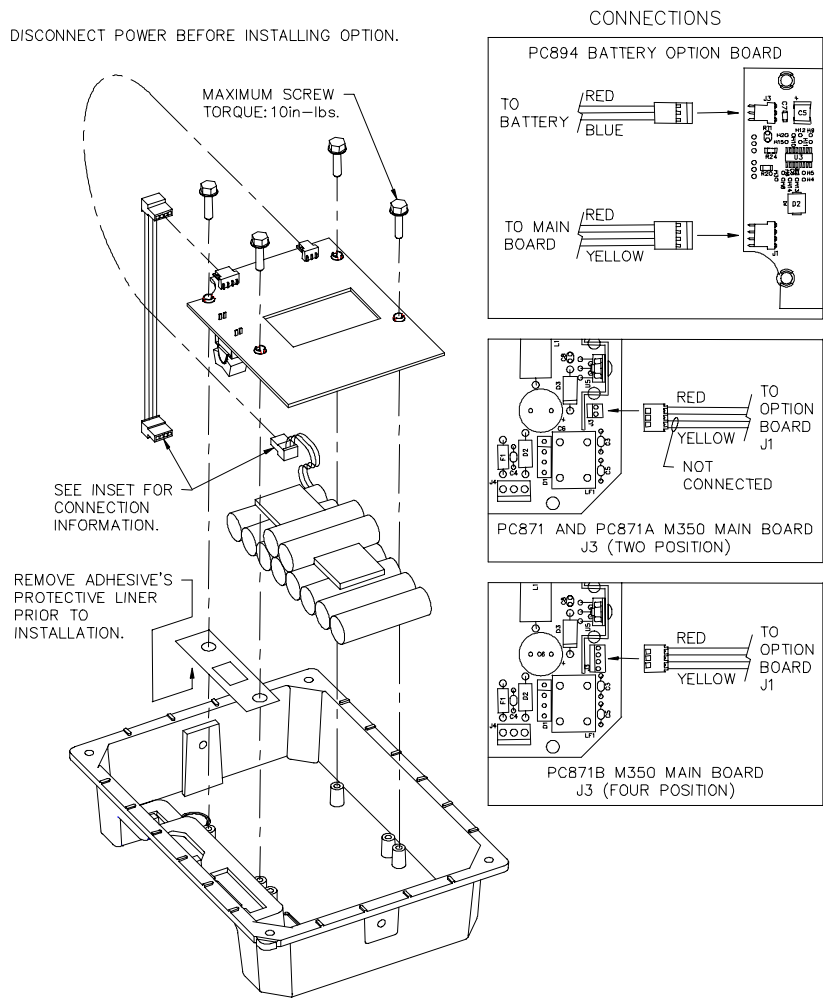

Figure 27: Battery Option Installation (350 die cast)

PIN DESIGNATIONS

See Figure 28 for main board battery connections (J3).

PIN	DESCRIPTION
+	<i>Positive terminal (VDC signal input)</i>
-	<i>Negative terminal (VDC signal input)</i>
L	<i>Low battery indicator terminal (TTL output - +5V OK, 0V Lo Bat)</i>
S	<i>Shutdown</i>
<p>NOTE: Earlier die cast model's main board may have only 2 or 3 pins (no "L" or "S" pins).</p>	

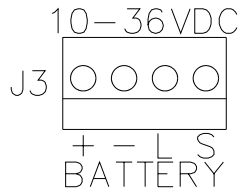

Figure 28: Model 350/355 Main Board Battery Connection

ON/OFF SWITCH

The on/off switch for the Model 350 die cast is a rocker-type switch that mounts in the center rectangular hole punch-out. The on/off switch for the Model 350/355 stainless is a toggle-type (washdown type) switch that replaces one of the available enclosure strain reliefs. The switch is soldered to the board (diecast) or on a cable (stainless).

The Model 350/355 will immediately switch to battery operation when AC power is interrupted if the switch is in the ON position. Placing the switch in the OFF position prevents the battery from running down when AC power is removed. The battery will be charged whenever there is AC power to the Model 350/355, regardless of the switch position.

INSTALLING THE ON/OFF SWITCH ON OLDER MODEL 350/355 STAINLESS STEEL INDICATORS

The 24350B-121B0 kit included a stainless steel washer and a rubber washer to allow mounting of the ON/OFF switch in 44-25-34840 revision.

A stainless steel enclosures. The switch was mounted in one of the holes for a PG9 size strain relief. The washers were used because the switch barrel diameter was much smaller than the hole diameter. The revision B enclosures have a PG7 size strain relief hole which allows mounting of the switch without the washers. Current Model 350/355 production has switched to the revision B enclosures. The washers are not included in the version 2 option kits for this reason. If you are retrofitting an older Model 350/355 Stainless Steel Indicator, please contact your sales representative to get one each of the following GSE part numbers:

- 36-20-2450 Rubber washer, 0.49 ID x 1.06 OD x 0.093 thick
- 36-20-2455 Stainless washer, 0.5 ID x 1.125 OD x 0.062 thick

BATTERY CHARGING

If needed, the battery will always be charging when the unit is plugged in, regardless of the switch position. Typically, it takes four hours to fast charge a fully discharged battery.

Battery voltage is monitored to provide a fast charge then a continuous trickle charge to maintain the battery while not in use.

OVERCHARGE PROTECTION

The battery state is monitored by the charging circuit to prevent overcharge and provide proper charge termination. Overcharging is also prevented through temperature sensing.

Battery voltage is monitored during charging to ensure a 100 percent capacity charge. The circuitry includes a safety timer to stop battery fast charging after 264 minutes.

TEMPERATURE SENSING

If the ambient temperature sensor RT1 on the board is colder than 10 degrees C, the battery will trickle charge and not enter fast charge until the temperature rises above 10°C (50°F).

If the battery temperature sensor (connected between battery – and THERMISTOR) is warmer than 60°C (140°F), the charger will stop fast charging and revert to trickle charging. A fast charge cannot happen again until the battery has cooled and the unit is reset by turning off the ON/OFF switch and interrupting the AC power to the Model 350/355.

LOW BATTERY INDICATION

The Low Battery indication occurs when the battery is discharged below 11.4 VDC. Parameter 426 enables or disables the low battery indication. Low battery will be indicated continuously if this feature is enabled without the battery option installed.

DISPLAY INDICATION

An Model 350/355 with LED display will flash “LoBat” on the display as a warning when the battery is low. An Model 350/355 with LCD display will turn on the square indicator between the MOTION and GROSS indicators on the bottom of the display. LOBAT is written above the indicator on the LCD lens.

REQUIRED HARDWARE

You must have the following hardware in order to use low battery indication:

- Model 350 Diecast:
PC871B Main Board (4 positions on J3)
450350-01006 Revision 6 EPROM (or newer)
- Model 350/355 Stainless:
PC891A Main Board (J3 3 position)
PC909 Main Board (J3 4 position)
450350-01006 Revision 6 EPROM (or newer)

DEAD BATTERY SHUTDOWN

The battery option disconnects battery power to the Model 350/355 before erratic operation can occur. The shutdown occurs at a battery voltage of 10 VDC. The switch must be clicked from ON to OFF to ON again to activate battery power after it has shut down. This feature is part of the circuitry on the battery option board. The Model 350/355 Main Board type and EPROM version do not affect its use.

AUTOMATIC SHUTDOWN

The Battery Option System Version 2 has an automatic power off feature that is enabled by parameter 427. This feature allows the Model 350/355 to shut itself off using a programmable time period of inactivity on the scale. The choices for the time period are in minutes: 0.5, 1, 2, 3, 4, 5, 10, 15, 20, 25, 30, 35, 40, 45, and 60.

You must have the following hardware in order to use the auto power off feature:

- Model 350 Diecast:
PC871B Main Board (J3 4 position)
450350-01006 Revision 6 EPROM (or newer)
- Model 350/355 Stainless:
PC909 Main Board (J3 4 position)
450350-01006 Revision 6 EPROM (or newer)

Version 1 kits (GSE P/N: 24350B-120B0-- Zinc Die Cast Model and GSE P/N: 24350B-121B0-- Stainless Steel Model) do not support automatic shutdown.

The original option kits included revision A of the battery option board, PC894. This board did not have the automatic power off feature. The automatic power off feature cannot be added to this version of the option kit. All of the other features listed above will function with this version.

Splash Guard Protection

The GSE Dura-Shield (GSE part # 31-70-35578) provides front panel protection for a 350 stainless steel enclosure used in heavy washdown environments. A clear Lexan® cover, the GSE Dura-Shield adheres to the metal portion of the front panel and not to the display lens or keypad, shielding the 350 from the elements while leaving the display unobscured, the keys easily pressed. The Lexan® is abrasion and chemical attack resistant, and non-yellowing.



Use caution when installing any equipment into a washdown environment. Be sure to use a pressure relief valve (PN# 44-30-5531).

International Transformer - IEC

The Model 350 zinc die cast transformer (GSE P/N 20-20-35190) allows the 350 to run on overseas current. Mounting tabs and line cords provide installation flexibility, allowing easy mounting to walls, tables, shelves, etc.



Transformers are available for Zinc Die Cast models only.

SPECIFICATIONS

- Operates on 230VAC input at 50 hz with an output of 20VAC @ 1 Amp max.
- Cord length from transformer to indicator is six feet (two meters) and includes the standard 3-prong Model 350/355 input plug.
- Cord length from the transformer to the IEC (male) plug end is another six feet (two meters).

TRANSFORMERS AVAILABLE

- Model 350 Zinc Die Cast Transformer (GSE part # 20-20-35190)

IEC LINE CORDS AVAILABLE

- GSE part # 22-30-1022 – for use in Australia, Argentina, New Zealand, and China
- GSE part # 22-30-1023 – for use in Chile and Italy

NOTE: The transformers can be ordered separately or with an instrument specified below:

- Model 350 Zinc Die Cast LED Display (GSE P/N 200350-28010)
- Model 350 Zinc Die Cast LCD Display (GSE P/N 200235-28020)

CHAPTER 4: CONFIGURATION





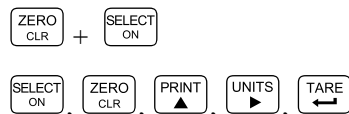

Entering the Setup Mode (Model 350)

To prevent accidental changes to the Indicator Setup, a sequence of keystrokes is used to gain access to the Setup Mode:





These keystrokes must be made within five seconds, or the indicator will return to the Weigh Mode.

To access the Setup Mode:

1. From the Weigh Mode, press  + 
DISPLAY READS ► Setup ~ Enter Code
2. Press 
DISPLAY READS ► S
3. Press 
DISPLAY READS ► SZ
4. Press 
DISPLAY READS ► SZP
5. Press 
DISPLAY READS ► SZPU
6. Press 
DISPLAY READS ► Chgs ~ Poss!
P110.— — ~ F.S.= ~ 100

To access Setup in a view-only mode:

1. From the Weigh Mode, press  + 
DISPLAY READS ► Setup ~ Enter Code
2. Press 
DISPLAY READS ► No ~ Chgs
P110.— — ~ F.S.= ~ 100



When exiting the Setup Mode, the Model 350/355 prompts whether to enter the Calibration Mode. (See *Chapter 5: Calibration* for Calibration Mode procedures). The display will then prompt to save any changes.

Entering the Setup Mode (Model 355)

To prevent accidental changes to the Indicator Setup, a sequence of keystrokes is used to gain access to the Setup Mode:

1 0 0

2 3 6 4 0

These keystrokes must be made within five seconds, or the indicator will return to the Weigh Mode.

To access the Setup Mode:

- From the Weigh Mode, key in 1 0 0
DISPLAY READS ► Setup ~ Enter Code
- Key in 2 3 6 4 0
DISPLAY READS ► Chgs ~ Poss!
P110.— — ~ F.S.= ~ 100

To access Setup in a view-only mode:

- From the Weigh Mode, key in 1 0 0
DISPLAY READS ► Setup ~ Enter Code
- Press
DISPLAY READS ► No ~ Chgs
P110.— — ~ F.S.= ~ 100

Selecting a Parameter

To advance to the next parameter:

- Press
DISPLAY READS ► P111.09 ~ 1Grad ~ 0.01
- Press
DISPLAY READS ► P112.05 ~ Ztrac ~ 0.5 d
- Continue pressing to advance through all setup parameters.



To access the previous parameter (Model 350):

- Press

DISPLAY READS ►.

2. Press 

DISPLAY READS ► P111.09 ~ 1Grad ~ 0.01

3. Repeat   to back up one parameter.



To access the previous parameter (Model 355):

1. Press 

DISPLAY READS ►.

2. Press 

DISPLAY READS ► P111.09 ~ 1Grad ~ 0.01

3. Repeat   to back up one parameter.



When accessing a parameter, the parameter number appears briefly. The display then toggles between the parameter name and selection. Pressing  will again briefly display the parameter number.

To access a specific parameter (for example P200) (Model 350):

1. Press  four times to select the first digit.

DISPLAY READS ► 2

2. Press  to advance to the next digit.

DISPLAY READS ► 2.

3. Press  once to select the next digit.

DISPLAY READS ► 20

4. Press  to advance to the next digit.

DISPLAY READS ► 20.



5. Press  once to select the next digit.

DISPLAY READS ► 200

6. Press  to advance to the parameter.

DISPLAY READS ► P200.00 ~ Baud ~ 9600



To access a specific parameter (for example P200) (Model 355):

1. Key in    

DISPLAY READS ► P200.00 ~ Baud ~ 9600

Changing a Parameter Value





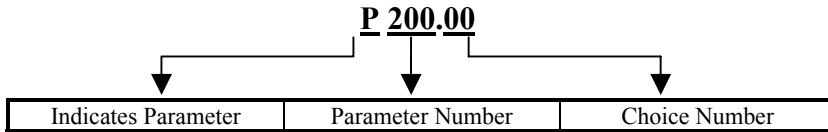

SELECTION PARAMETERS

Selection parameters have a pre-defined list of choices to pick from. Each choice is numbered and corresponds to a certain value. The choice number is shown to the right of the decimal point within the parameter number. Repeatedly pressing  (Model 350) or  (Model 355) while viewing a selection parameter cycles through the available choices, or you can key in the choice number.



For example, parameter 200 is a selection parameter that holds the baud rate for the serial. This is a selection parameter because a choice number between 00 and 06 must be used. Each choice number corresponds to a different baud rate. To change the baud rate from the default value of 9600 to 4800, perform the following steps from the Setup Mode.

To change the baud rate from the default value of 9600 to 4800:



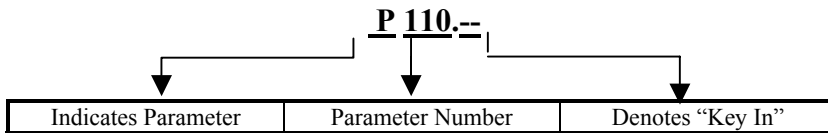

1. Key in    .
- DISPLAY READS ► P200.00 ~ Baud ~ 9600**
2. Press  (Model 350) or  (Model 355) once.
- DISPLAY READS ► P200.01 ~ Baud ~ 4800**

Key-In Parameters

Key-In Parameters are not limited to a list of choices, although there may be upper and lower value limits. A Key-In Parameter requires that a numeric value be entered using the front panel keys. Key-In Parameters are shown with two hyphens after a decimal point within the parameter number.









To enter a Key-In Parameter (350):

1. Press . A decimal point is used to represent the entry position.
2. Press  until the desired character appears.
3. Press . Another decimal point indicates the next entry position.
4. Repeat steps 1 and 2 until your desired entry value is shown.
5. Press  to enter your numerical value.





To enter a Key-In Parameter (355):

1. Key in the number by using the numeric keys.
2. Press  to accept the entry.

To setup a full scale value of 250 lbs (350):



1. Access the setup mode.
DISPLAY READS ► P110.— — ~ F.S.= ~ 100
2. Press  four times to select the first digit.
DISPLAY READS ► 2
3. Press  to advance to the next digit.
DISPLAY READS ► 2.
4. Press  six times to select the next digit.
DISPLAY READS ► 25
5. Press  to advance to the next digit.
DISPLAY READS ► 25.
6. Press  once to select the next digit.
DISPLAY READS ► 250
7. Press  to enter the value.
DISPLAY READS ► P110.— — ~ F.S.= ~ 250



To setup a full scale value of 250 lbs (355):

1. Access the setup mode.
DISPLAY READS ► P110.— — ~ F.S.= ~ 100
2. Key in   to accept the entry.
DISPLAY READS ► P110.— — ~ F.S.= ~ 250





Saving Parameters

To exit the Setup Mode and save changes (350):



1. Press  to begin exiting Setup Mode.
DISPLAY READS ► Enter ~ =CAL!
2. Press  to bypass Calibration Mode.
DISPLAY READS ► Enter ~ =Stor

3. Press  to save setup changes.
DISPLAY READS ► *Enter ~ =End*
4. Press  to complete exit.
DISPLAY READS ► *0.00*





To exit the Setup Mode and save changes (355):

1. Press  to begin exiting Setup Mode.
DISPLAY READS ► *Enter ~ =CAL!*
2. Press  to bypass Calibration Mode.
DISPLAY READS ► *Enter ~ =Stor*
3. Press  to save setup changes.
DISPLAY READS ► *Enter ~ =End*
4. Press  to complete exit.
DISPLAY READS ► *0.00*





To exit the Setup Mode from the view-only mode (350):

1. Press  to begin exiting Setup Mode.
DISPLAY READS ► *Enter ~ =End*
2. Press  to complete exit.
DISPLAY READS ► *0.00*

To exit the Setup Mode without saving changes (350):

1. Press  to begin exiting Setup Mode.
DISPLAY READS ► *Enter ~ =CAL!*
2. Press  to bypass Calibration Mode.
DISPLAY READS ► *Enter ~ =Stor*
3. Press  to exit *without* saving changes.
DISPLAY READS ► *Enter ~ =Undo*
4. Press  to undo changes.
DISPLAY READS ► *Enter ~ =End*
5. Press  to complete exit.
DISPLAY READS ► *0.00*

















To exit the Setup Mode without saving changes (355):

1. Press  to begin exiting Setup Mode.
DISPLAY READS ► Enter ~ =CAL!
2. Press  to bypass Calibration Mode.
DISPLAY READS ► Enter ~ =Stor
3. Press  to exit *without* saving changes.
DISPLAY READS ► Enter ~ =Undo
4. Press  to undo changes.
DISPLAY READS ► Enter ~ =End
5. Press  to complete exit.
DISPLAY READS ► 0.00

















Factory Default

Parameter 65001 and 65002 are available to return the Model 350 to factory settings. Parameter 65001 will reset parameters including the calibration, while parameter 65002 resets all parameters except the calibration.

To change the baud rate from the default value of 9600 to 4800 (350):

1. Key in  or  
DISPLAY READS ► P65002~default-Cal
2. Press  once.
DISPLAY READS ► Are U sure?~default=Enter
3. Press  once.
DISPLAY READS ► Setup done~P65002~default-Cal
4. Press 

To change the baud rate from the default value of 9600 to 4800 (355):

1. Key in  or  
DISPLAY READS ► P65002~default-Cal
2. Press  once.
DISPLAY READS ► Are U sure?~default=Enter
3. Press  once.
DISPLAY READS ► Setup done~P65002~default-Cal
4. Press 

List of Parameters

The Model 350 and Model 355 have several parameters that can be configured to your specific application. Below is a table of the available parameters. Also refer to page 48 for explanations of each parameter.

Table 11: Parameter Map

Parameter Number	Display Name	Default Value	Valid Range/ Choices	Parameter Description	Page
P110.--	<i>F.S.=</i>	100.00	.01 – 999,999 (Keyed In)	Full Scale	48
P111.09	<i>lGrad</i>	.01	.00001 – 500 (24 Selections)	Count By	48
P112.05	<i>Ztrac</i>	0.5d	Off - 20.0d (200 Selections)	Zero Track Aperture	48
P114.10	<i>Stabl</i>	1.0d	Off – 20.0d (200 Selections)	Stability Window	48
P116.04	<i>Filtr</i>	1 Sec	.065 – 8.00 Sec (8 Selections)	Filter Setting	49
P117.01	<i>Rate=</i>	0.1 Sec	0.05 – 20.0 Sec (201 Selections)	Display Update	49
P118.12	<i>Zrang</i>	100%	.01 – 100% (13 Selections)	Zero Button Range	49
P150.00	<i>Units</i>	lb	lb / kg (Toggle)	Default (Calibration) Units	49
P151.01	<i>Unbut</i>	Enable	Enable / Disable (Toggle)	Units Button	49
P152.00	<i>Unit3</i>	None	None / ounce / gram / lb oz (4 Selections)	Additional Unit	49
P161.00	<i>TarSa</i>	Disable	Enable / Disable (Toggle)	Tare Save	49
P166.01	<i>AutoT</i>	Enable	Enable / Disable (Toggle)	Auto Tare	49
P169.00	<i>AtClr</i>	Disable	Enable / Disable (Toggle)	Auto Tare Clear	50
P171.00	<i>AnAlg</i>	Disable	Enable / Disable (Toggle)	Analog Output Option	50
P179.00	<i>Count</i>	Disable	Enable / Disable (Toggle)	Counting Functions	50
P200.00	<i>Baud</i>	9600	150 – 9600 (7 Selections)	Comm Baud Rate	50
P201.01	<i>Data</i>	8 Bits	7 – 8 Bits (2 Selections)	Comm Data Bits	50
P202.00	<i>Par'y</i>	None	None – Odd (3 Selections)	Comm Parity	50
P203.00	<i>Stop</i>	1 Bit	1 – 2 Bits (2 Selections)	Comm Stop Bits	50
P204.02	<i>HndSh</i>	Soft	None – Both (4 Selections)	Comm Handshake	50
P210.01	<i>Send</i>	Press	Off – Cycle (4 Selections)	Comm Transmit	50
P212.01	<i>Stabl</i>	Delay	Off – Delay (Toggle)	Comm Motion	50
P213.01	<i>TrTyp</i>	--1--	0 – 13 (Selection)	Print Transmission	50
P250.00	<i>RS485</i>	Disable	Enable / Disable (Toggle)	Network Option	50
P251.00	<i>Addr</i>	Disable	Disabled and 4 – 254 (Key In)	Network Address	51



Parameter Number	Display Name	Default Value	Valid Range/ Choices	Parameter Description	Page
P410.--	<i>Euro</i>	Disable	Enable / Disable 9991/9990 (Key In)	OIML Enforce	51
P420.01	<i>Dsply</i>	On	Off – Auto (3 Selections)	Display Function	51
P423.00	<i>Backlight</i>	Off	ON/OFF (Toggle)	Backlight	51
P426.00	<i>Batt</i>	Disable	Enable / Disable (Toggle)	Battery Option annunciator	51
P427.00	<i>Apo</i>	Off	Off – Cycle (15 Selections)	Auto Power for Battery Option	51
P440.00	<i>rStrc</i>	Disable	Enable / Disable (Toggle)	NTEP Enforce	51
P502.01	<i>disbl t-dAt</i>	Disable	Enable / Disable (Toggle)	Time/Date Function	51
P503.01	<i>12 hours</i>	12 hour	12 hour/24 hour	Time/Date Function	51
P504.00	<i>Style</i>	U.S.A	U.S.A or International	Time/Date Function	52
P505.01	<i>TdSEL disbl</i>	Disable	Enable / Disable (Toggle)	Time/Date Function	52
P800.00	<i>R-But</i>	None	None – Setpoint (5 Selections)	Remote Button Function	52
P1000.--	<i>Cust. Trans</i>	--	--	Custom Transmit	51
P5010.00	<i>SPAnn</i>	Enable	Enable / Disable (Toggle)	Setpoint Annunciators	52
P5011.00	<i>SPBar</i>	Disable	Enable / Disable (Toggle)	Bargraph Display	52
P5012.00	<i>BarPc</i>	50%	0 – 100 (Key In)	Bargraph Scaling	53
P5100.00	<i>SetPt</i>	None	None – Indep (8 Selections)	Setpoint Operation	53

PARAMETER MAP DETAILS

P110 Full Scale Value (Key in)

Denotes the full scale capacity. This value should not exceed the rated capacity of the weighing device.

P111 Division Size (Selection)

Indicates the count-by and decimal point. Pressing  +  (Model 350) or  (Model 355) will automatically select the choice closest to 10,000 divisions without exceeding 10,000 divisions.

P112 Zero Track Aperture (Selection)

Set in terms of number of divisions. Zero tracking eliminates small weight deviations at or near zero. Weight deviations within the selected window that have been stable for more than one second are tracked off, maintaining a gross or net zero condition.

The sum of weight values zeroed with auto zero tracking and  cannot exceed the allowable zero range (P118).

Truck scales commonly use zero tracking to compensate for snow fall. To determine the proper setting in a counting application, divide the weight of the smallest product counted by the division size (P111). Zero Track should be set to 0 (off) for most setpoint filling operations. This prevents tracking off any product trickle at the start of a fill process.

P114 Stability (Selection)

Stability is defined as weight fluctuations within an aperture that can be regarded as being a stable weight. Deviations outside this aperture are considered motion, and the motion annunciator on the front panel will light accordingly. Once the scale settles within the stability aperture, the indicator will wait one second before the indicator is considered stable.

Print operations configured as motion delayed (P114) will not send the specified data until the weight reflects a stable reading as designated by this setting. Certain setpoint operations are also considered motion delayed and will not change states until a no-motion condition exists.

P116 Filter (Selection)

Sets the indicator response time in terms of seconds. Filtering determines how quickly the indicator will respond to changing input signals. A low filter setting speeds the response, a higher filter setting will ‘dampen’ the response.

Filtering is used to filter out weight fluctuations caused by outside sources, such as vibrations or air currents.

P117 Rate (Selection)

Specifies how often the display is updated with new data. For example, if 0.05 is selected, the controller will write data to the display every time an analog/digital conversion is made. Since the A/D converter updates every 0.05 sec, selections from 0.05 to 20.0 seconds are available. This parameter also affects the transmission rate for continuous transmit. Actual transmission intervals are dependent upon system setup.

P118 Zero Range (Selection)

Specifies how many divisions can be zeroed in terms of a **percentage** of full scale (P110). The sum of weight values zeroed through the  key and auto zero tracking cannot exceed this range.

A zero range of 5% is commonly used with large tank scales to avoid accidental zeroing of a full or partially full tank.

P150 Units (Toggle)

Set default units to ‘lb’ or ‘kg’. The indicator must use the default units during calibration procedures (see *Chapter 4*). The default units are the displayed units upon indicator power-up.

P151 Units Button (Toggle)

When enabled, this parameter will allow  to toggle the units between ‘lb’ and ‘kg’ (1000g). When disabled, the indicator will show only the calibration units as determined by P150.

P152 Third Unit (Selection)

This parameter will allow the choice of three additional units (ounces, grams or lb oz) that may be accessed with the  key. Only one unit will be available at a time. The third unit can only be selected if P151 is enabled. The third unit will be identified by an annunciator on the display. This unit selection is not legal for trade.

P161 Tare Save (Toggle)

Enabling Tare Save allows the indicator to retain the tare value in the event of power loss. The correct net weight is restored upon power-up.

P166 Auto Tare (Toggle)

When enabled, pressing  will wait for a no-motion condition and then bring the scale to a net zero reading. Disabling will prevent keypad tare operations.



Note that if a setpoint activation method is set to , disabling Auto Tare will also disable the activation of that setpoint.

P169 Auto Tare Clear (Toggle)

Enabling this feature will cause the current tare value to be cleared to zero every time the indicator stabilizes within ± 5 graduations of gross zero

P171 Analog (Toggle)

Enable or disable the optional analog output module. See *Analog Output Setup* on page 23 for all parameters associated with the Analog Output Module.

P179 Count (Toggle)

When enabled, the quantity mode becomes accessible via the  key. The quantity mode is identified by the illumination of the QTY annunciator.

P200 Baud (Selection)

Set the desired baud rate for the communication port.

P201 Data Bits (Toggle)

Select 7 or 8 data bits for the transmission.

P202 Parity (Selection)

Select *Odd*, *Even* or *None* for the transmission parity.

P203 Stop Bits (Toggle)

Select 1 or 2 stop bits for communication port transmissions.

P204 Comm Handshake (Selection)

Select from *None*, *Software (Xon/Xoff)*, *Hardware (CTS/RTS)*, or *Both*.

P210 Send (Selection)

Transmission Send options:

Choice Number	Selection Name	Description
P210.00	<i>Off</i>	All transmissions disabled.
P210.01	<i>Press</i>	Sends transmission with [PRINT] key.
P210.02	<i>Cont.</i>	Sends transmissions continuously.
P210.03	<i>Cycle</i>	Send single transmission after weight is reached and motion ceases. Must return display value below 0.1% of F.S. to reset for next transmission.

P212 Send Stability (Toggle)

Enabling Send Stability will delay any transmissions until a no-motion condition exists.

P213 Transmit Selection (Selection)

Select desired print output (0 – 14). The transmission will be initiated by the selected print operation (P210) and / or the Remote Key selection (P800). See page 53 for more details on the available preset transmits.

P250 RS-485 Multi-Drop Network (Toggle)

Enable / disable the RS-485 multi-drop network option. Requires that an RS-485 option board be installed. This option allows up to 250 RS-485 devices to be networked together in either a half duplex or full duplex wiring scheme. See the RS-485 Multi-Drop Network Setup and Operation section beginning on page 86 for complete details on RS-485 setup and operation.

P251 Address (Key in)

Specifies the address of the controller for RS-485 multi-drop communications. Allowed choices are 0 (disabled) and 4 – 254.

P410 Euro (Toggle)

Enable OIML legal-for-trade restrictions (see *Chapter 6: Legal For Trade*).

P420 Display (Selection)

Select display control option. Choose from *On*, *Off* or *Auto*. The auto setting helps conserve power for extended battery life. When the indicator display is off, the load cell(s) are still powered.

If P420 is set to *Off* or selection 0, you can turn on the display by holding down the ZERO key upon power up.

This does not set P420 to *On*; it only temporarily turns on the large VFD display in order to allow you to see what you are entering.

Parameter Setting	Choice	Description
P420.00	<i>Off</i>	Shuts off the display.
P420.01	<i>On</i>	Normal display operation.
P420.02	<i>Auto</i>	Shuts off the display when weight has stabilized within 6 divisions for 5 minutes. Pressing [ON] or changing weight more than 6 divisions will re-enable the display. NOTE: The display will turn back on if data is received via the RS-232 Port.

P423 Back Light (on/off)

Toggle the backlight on a 350/355 LCD

P426 Low Battery Indication (Toggle)

Press TARE to enable or disable this option. Low battery will be indicated continuously if this feature is enabled without the battery option installed. Otherwise, an annunciator will be lit when the battery voltage is low.

P427 Battery Option Automatic Shutdown (Selection)

Select duration of time for auto shutdown. Choose from selections with the TARE key. Selections are off, 0.5, 1, 2, 3, 4, 5, 10, 15, 20, 25, 30, 35, 40, 45, and 60. Choices are in set in minutes.

P440 Legal For Trade Restrictions (Toggle)

Enable NTEP legal-for-trade restrictions. See *Chapter 6: Legal For Trade*.

P502 Time/Date (toggle)

Enables or disables the time and date feature. If enabled the indicator will prompt the user to enter the correct date and time upon power up. Note: if disabled P503-P505 will not be accessible, however, their current settings will be retained for future use.

P503 Hours (toggle)

Determines the TIME format style, 12 hour or 24 hour. If in 12 hour mode the right most decimal point on the LED display will become the PM indicator. Note: The time must be entered as military time. If the mode is set for 12 hour, the time will be converted to a 12 hour clock.

P504 Style (toggle)

Determines the DATE format style, U.S.A. or Int'l. If set for U.S.A, the date will resemble 01/26/01. If set for international, the date will resemble 26/01/01.

P505 Time/Date Select (toggle)

Allows the time and date to be viewed with the  key from the weigh mode. The weight will continue to be updated when viewing the time or date. The time will be formatted as defined by P503 and the date will be formatted as defined by P504

P800 Remote Key Operation (Selection)

Select function for Remote Key closure. Choose from *None*, *Print*, *Tare* or *Zero*. If a setpoint is configured to use the remote key as an activation method, then the P800 setting is over-ridden. The *Remote Key Operation* section on page 83 details the remote key operation. See *Remote Key Connection* on page 12 for remote key electrical connections.

P1000 Custom Transmit

of the custom transmit table and must be enabled for transmit by selecting choice 0 at P213. Parameters use three bytes of memory; ASCII characters and control codes use one byte. See P60001 for available memory. The custom transmit cannot be viewed or altered from the indicator. A custom transmit *must* be entered via the serial port. See *Custom Transmit Setup* on page 55 for details on designing and loading a custom transmit.

P5000 355 Target Key (Toggle)

Allows a target value to be entered or viewed. This parameter will only appear when a 355 keypad is detected. Sending a %g using a serial device such as a computer is equivalent to pressing the Target key.

P5002 355 Stop Key (Toggle)

Enable or disable the use of the stop key from the 355 keypad. This parameter will only appear when a 355 keypad is detected. Sending a %h using a serial device such as a computer is equivalent to pressing the Stop key.

P5003 355 Start Key (Toggle)

Enable or disable the use of the start key from the 355 keypad. Pressing the Start key in the weigh mode with setpoints enabled causes a paused setpoint operation to be resumed. In setpoint modes other than checkweighing, the Start key performs the same operation as a remote key. This parameter will only appear when a 355 keypad is detected. Sending a %y using a serial device such as a computer is equivalent to pressing the Start key.

P5004 355 Restart Checkweighing Mode (Toggle)

Determines the method in which the checkweighing mode will be restarted. Auto will restart after return to zero or Manual will restart by pressing the  key.

P5010 Setpoint Annunciators (Toggle)

Enables or disables the setpoint annunciators to the left of the main 7-segment display. Disabling the setpoint annunciators may be desired when the bargraph is enabled while using an LCD display. See *Bargraph (General)* on page 66.

P5011 Setpoint Bargraph (Toggle)

Enables or disables the bargraph display on the LCD version of the Model 350/355 display. This setup parameter only appears if an LCD display is installed. See *Bargraph (General)* on page 66.

P5012 Setpoint Bargraph Low-Limit Percentage (Key in)

Controls the "bargraph low-limit percentage" value for determining the *weighting* of each segment of the bar graph. This only appears if an LCD display is installed. See *Bargraph (General)* on page 66.

P5100 Setpoint Operation (Selection)

Sets the desired Setpoint operation. Choose between *None, ChecP, Fill, Batch, Discharge, Both, ChecA* or *Independent*. See *General Setpoint Setup* on page 63 for complete details on setpoint setup and operation.

Preset Transmit Selections

The Model 350 and Model 355 provide 14 preset formats for printing tickets or sending data to a computer. Only one format or custom transmit may be enabled at a time.

Choice 0 Custom Transmit:

User-defined serial data string (see *Custom Transmit Setup* on page 55).

Choice 1 GSE Standard Transmit:

```
XXX.XX kg Gross<CR><LF>
XXX.XX kg Tare <CR><LF>
XXX.XX kg Net <CR><LF>
HH:MM:SS am MM/DD/YY <CR><LF>
```

Choice 2 Count:

```
HH:MM:SS am MM/DD/YY <CR><LF>
  XXX QTY <CR><LF>
  XX.X kg APW <CR><LF>
XXX.XX kg Gross<CR><LF>
XXX.XX kg Tare <CR><LF>
XXX.XX kg Net <CR><LF>
```

(NOTE: *The time and date will only be printed in choice 1 and 2 if P502 is enabled.*

Choice 3 (Condec Clone):

```
<STX> <POL> <DATA> <L/K> <G/N> <STAT> <CR> <LF>
```

Where:

<STX> is a single control code, decimal value of 2.

<DATA> is 8 characters, 1st character is either minus sign or a space, padded with leading spaces, with an embedded decimal point.

<L/K> is a single 'L' or 'K' character to indicate lb or kg units.

<G/N> is a single 'G' or 'N' character to indicate gross or net data.

<STAT> is an 'O' (overload/underload), 'M' (motion), or space otherwise.

<CR> is a single control code (carriage return), decimal value of 13.

<LF> is a single control code (line feed), decimal value of 10.

Choice 4:

```
<STX><SignedDATA><sp><lb/kg><sp><Gross/Net/Qty><STAT><CR>
```

Choice 5:

```
<STX><Signed DATA><sp><lb/kg><STAT><CR>
```

Choice 6:

```
<STX><Signed DATA><sp><lb/kg><CR>
```

Choice 7:

<STX><Unsigned DATA><sp><CR>

Choice 8:

<STX><Signed DATA><sp><lb/kg><sp><Gros/Net/Qty><STAT><SPS><CR>

Choice 9:

<STX><Signed DATA><sp><lb/kg><STAT><SPS><CR>

Choice 10:

<STX><Signed Displayed Weight><sp><lb/kg><SPS><CR>

Choice 11:

<STX><Unsigned Displayed Weight><SPS><CR>

Choice 12:

<STX><Unsigned DATA><sp><lb/kg><sp><Gross/Net/Qty><STAT><CR>

Use choice 12 to send to a 450/455/550 remote display that is set to text mode and a <CR> terminator.

Choice 13:

<STX><Unsigned DATA><sp><lb/kg><sp><Gross/Net/Qty><STAT> <CR><LF>

Choice 14 (Simulates NCI 3835):

<LF>Signed DATA<CR><LF><STAT><CR><ETX>

Data Block Name	Description
<STX>	A single control code, decimal value of 2.
<ETX>	A single control code, decimal value of 3.
<POL>	A <space> for positive data or a - for negative data.
<Signed DATA>	8 characters right justified, space padded, including a decimal point and polarity sign. Polarity is a '+' or '-' to the immediate left of the most significant digit.
<Unsigned DATA>	8 characters right justified, space padded, including a decimal point.
<lb/kg>	Two characters indicating pounds or kilograms.
<Gross/Net/PTY>	Single word for gross weight, net weight or quantity.
<STAT>	An 'O' (overload/underload), 'M' (motion), or <space> otherwise
<SPS>	See <SPS> Setpoint Status below.
<CR>	A single control code, decimal value of 13.
<LF>	A single control code, decimal value of 10.
<sp>	ASCII Space, decimal value of 32.

<SPS> Setpoint Status

Transmitting the setpoint status will reflect the current state of all the setpoints, regardless of which setpoint operation is configured. The status can be read as a single ASCII numeric character (0-7), a Hex value (30h-37h) or a binary bit comparison. Status is preceded by a <space> and an "S". The preceding data stream format is for fixed transmissions of <SPS> as specified above. This is not associated with the custom transmission of parameter P96.

SP 1	SP 2	SP3	ASCII	Hex	Bit Comparison
Off	Off	Off	0	30h	0011 0000
On	Off	Off	1	31h	0011 0001
Off	On	Off	2	32h	0011 0010
On	On	Off	3	33h	0011 0011
Off	Off	On	4	34h	0011 0100
On	Off	On	5	35h	0011 0101
Off	On	On	6	36h	0011 0110
On	On	On	7	37h	0011 0111

Custom Transmit

The serial output of the Model 350/355 can be configured for a custom application such as a remote display format, a customized computer program format, or a customized ticket format. The custom transmit must be designed in a computer-transmittable ASCII text file. The custom transmit can only be loaded into the indicator through the serial port. P213 must be set to 0 to select the custom transmit format for transmission.

ELEMENTS OF A CUSTOM TRANSMIT

Parameters, ASCII text, and control codes are the elements of a custom transmit.

Parameters

Certain parameters related to weight, quantity, setpoints and status can be sent out of the comm port. Gross Weight, Target 1 and Quantity are examples of printable parameters.

ASCII Text

ASCII text can be entered into a custom transmit to provide further detail of a transaction. “P”, “@” and “+” are examples of ASCII text.

Control Codes

You can custom transmit ASCII control codes to control a printing device. <CR> (carriage return) and <FF> (form feed) are examples of control codes.

WRITING A CUSTOM TRANSMIT ASCII TEXT FILE

Any text editor may be used to construct a custom transmit (Notepad, Wordpad, etc.), but you must save the custom transmit as a text (.txt) file. Instructions can also be sent keystroke by keystroke from a communications program. To do so, ignore the Model 350/355 display and enter the characters in the correct order. *Figure 29* shows a custom transmit written in Wordpad.

ACCESSING SETUP AND CLEARING EXISTING CUSTOM TRANSMIT

Every custom transmit file must start with:

```
1999%s%s%z%p%u%e
%c%e
```

This accesses the Setup Mode at the end of the existing transmit and then clears the transmit so that a new one may be entered.

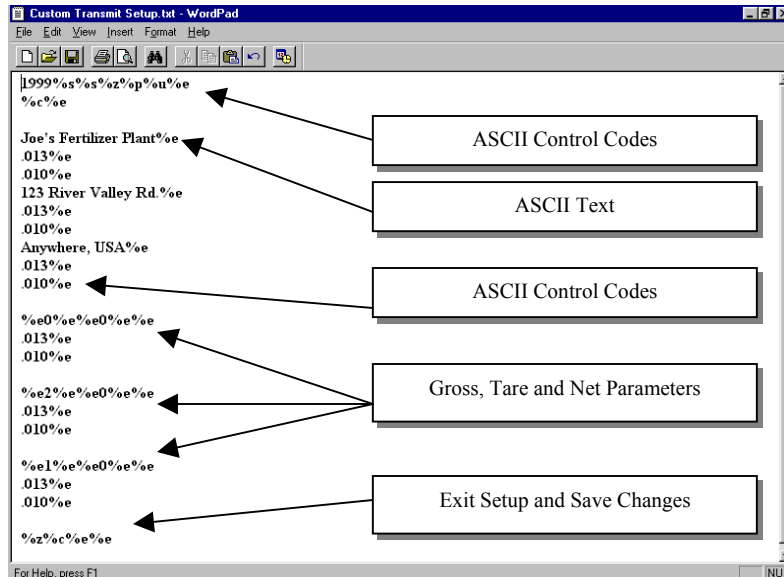

Figure 29: Custom Transmit File

ENTERING ASCII TEXT

ASCII text is defined as printable characters, including alpha-numeric as well as punctuation and symbols. See Table 14 for a complete listing of ASCII characters. ASCII text can be entered directly into a custom transmit with a %e (enter command). For example, **Joe's Fertilizer Plant%e**.

ENTERING ASCII CONTROL CODES

Some ASCII characters are known as control codes, non-printable characters that instruct a printing device to perform certain functions. For example, a carriage return <CR> forces a printer to move the print head to the left-most position of the current line. A line feed <LF> forces the print head to move down one line. Enter control codes with a decimal point, a 3-digit ASCII code, and a %e. For example, **.013%e**.



Most printers require a carriage return (.013) and/or a line feed (.010) to print preceding data and avoid leaving data in the printer buffer. See Table 12 for a list of ASCII codes.

Table 12: ASCII / HEXADECIMAL CONVERSION CHART

										HEX	CHAR	DEC		
00	NUL	000	1A	SUB	026	34	4	052	N	078	68	h	104	
01	SOH	001	1B	ESC	027	35	5	053	4F	O	079	69	i	105
02	STX	002	1C	FS	028	36	6	054	50	P	080	6A	j	106
03	ETX	003	1D	GS	029	37	7	055	51	Q	081	6B	k	107
04	EOT	004	1E	RS	030	38	8	056	52	R	082	6C	l	108
05	ENQ	005	1F	US	031	39	9	057	53	S	083	6D	m	109
06	ACK	006	20	SP	032	3A	:	058	54	T	084	6E	n	110
07	BEL	007	21	!	033	3B	;	059	55	U	085	6F	o	111
08	BS	008	22	"	034	3C	<	060	56	V	086	70	p	112
09	HT	009	23	#	035	3D	=	061	57	W	087	71	q	113
0A	LF	010	24	\$	036	3E	>	062	58	X	088	72	r	114
0B	VT	011	25	%	037	3F	?	063	59	Y	089	73	s	115
0C	FF	012	26	&	038	40	@	064	5A	Z	090	74	t	116
0D	CR	013	27	'	039	41	A	065	5B	[091	75	u	117
0E	SO	014	28	(040	42	B	066	5C	\	092	76	v	118
0F	SI	015	29)	041	43	C	067	5D]	093	77	w	119
10	DLE	016	2A	*	042	44	D	068	5E	^	094	78	x	120
11	DC1	017	2B	+	043	45	E	069	5F	_	095	79	y	121
12	DC2	018	2C	'	044	46	F	070	60	`	096	7A	z	122
13	DC3	019	2D	-	045	47	G	071	61	a	097	7B	{	123
14	DC4	020	2E	.	046	48	H	072	62	b	098	7C		124
15	NAK	021	2F	/	047	49	I	073	63	c	099	7D	}	125
16	SYN	022	30	0	048	4A	J	074	64	d	100	7E	~	126
17	ETB	023	31	1	049	4B	K	075	65	e	101	7F	DEL	127
18	CAN	024	32	2	050	4C	L	076	66	f	102			
19	EM	025	33	3	051	4D	M	077	67	g	103			

PARAMETER SELECTION NUMBERS

The following sequence enters parameters into a custom transmit: **%e**, the parameter number, **%e%e**, a format code, and then **%e%e** with no intervening spaces.

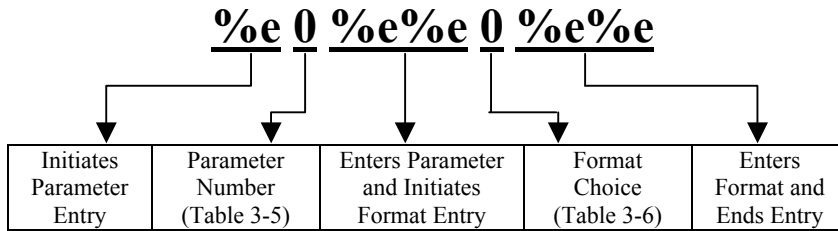

Table 13: Custom Transmit Parameter Selection Numbers

Parameter Name	Parameter Number	Sample Print Output
Gross Weight	0	27.49 lb Gross
Net Weight	1	14.53 lb Net
Tare Weight	2	12.96 lb Tare
Time / Date	11	10:01:01 am 01/26/01
Quantity	30	58 Qty
APW	34	0.25 lb APW
APW * K	35	250 lb APW * K
Targ1	60	400 lb Targ1
Targ2	64	500 lb Targ2
Targ3	66	1000 lb Targ3
Act 1 (note: Indp. SP1)	70	600 lb Act 1
Rst 1 (note: Indp. SP1)	71	10 lb Rst 1
Act 2 (note: Indp. SP2)	72	300 lb Act 2
Rst 2 (note: Indp. SP2)	73	10 lb Rst 2
Act 3 (note: Indp. SP3)	74	100 lb Act 3
Rst 3 (note: Indp. SP3)	75	5 lb Rst 3
Setpoint Status	96	Setpt 0
Stability Status	97	Stat M
Displayed Value	98	16.34 lb Gross

The default format code for all parameters is 0. This prints all numeric data with 8 characters, right justified, left spaces filled., the units (if applicable) and the parameter name. The format choices for all parameters (except Stability Status and Setpoint Status) are shown in Table 14.

Table 14: Custom Transmit Format Codes

Choice	Sample Print Result	Description
Weight Parameter Format Codes		
0	“ 27.49 lb Gross”	Fixed width (8 characters), right justified, left spaces filled.
1	“000027.49 lb Gross”	Fixed width (8 characters), right justified, left zeroes filled.
2	“27.49 lb Gross”	Fixed width, left justified, right spaces filled.
3	“27.49 lb Gross”	Minimum possible width.
8	“400. lb Net”	Print decimal point, even if data has no fractional portion.
16	“+400 lb Net”	Print “+” for positive numbers.
32	“336.52 Net”	Do NOT print parameter units (lb or kg).
64	“336.52 lb Net”	Print value in “default” units (as opposed to current viewed units).
128	“336.52 lb”	Do NOT print parameter name.

Time/Date Format Codes		
1	“10:07:40 am 01/26/01”	Includes seconds with time.
2	“10:08 01/26/01”	24 hour time format.
4	“10:11 am Jan 26, 2001”	Print date spelled out.
8	“10:12 am Fri 01/26/01”	Print day of the week.
16	“10:12 am 26/01/01”	International date format.
32	“980503984 Tm/Dt”	# of seconds since 12:00 AM Jan 1, 1970.
64	“01/26/01”	Do NOT print time.
128	“10:14 am”	Do NOT print date.

If a combination of format choices is required, add the choice numbers together and enter their sum as the format code. For example, to print the net weight without the name (Net) or units (lb) and to print it minimum width:

NOTE: Only one of the choices 0-3 may be used at one time.

Choice	Sample Print Result	Description
3	“336.52 lb Net”	Minimum possible width.
32	“336.52 Net”	Do NOT print parameter units.
128	“336.52 lb”	Do NOT print parameter name.
Use the sum of the desired choice selections: 3 + 32 + 128 = 163		
163	“336.52”	Minimum possible width. Do NOT print parameter units. Do NOT print parameter name.

EXITING SETUP MODE AND SAVING CHANGES

Each custom transmit file must end with:

%z%c%e%e

This exits the Setup Mode, bypasses the calibration procedure and saves the indicator configuration file.

Parts Counting

The counting parameter must be enabled before the quantity mode is available. Refer to page 50 for details on the counting parameter and page 40 to enter the setup mode, make changes and save the change.

To sample using selectable fixed counts:

- From the Weigh Mode, Press to view the current net weight.
DISPLAY READS ► 1.05
- Press until the QTY annunciator is lit. The display may show **do APS** the first few samples.
DISPLAY READS ► 0
- Press to perform an auto-tare. The scale prompts to add 10 pieces.
DISPLAY READS ► Add ~ 10
- Press to toggle sample amounts between 5, 10, 20, 50 and 100.
DISPLAY READS ► Add ~ 20
- Add the pieces to be sampled and press to sample and display the current quantity.

DISPLAY READS ► 20

To sample using variable counts:

1. From the Weigh Mode, Press to view the current net weight.

DISPLAY READS ► 1.05

2. Press to view the current quantity/count.

DISPLAY READS ► 0

3. Press to perform an auto-tare. The scale prompts to add 10 pieces.

DISPLAY READS ► Add ~ 10

4. Key in 36, then press to sample as 36 pieces and display the current quantity.

DISPLAY READS ► 36

Analog Output Setup

Table 15: Analog Output Parameters

Parameter Setting	Displayed Name	Description	Type/choices (*=Default)
P171.00	<i>AnAlg</i>	Enable analog option.	Disbl*, Enabl
P172.00	<i>AnPar</i>	Parameter that analog signal corresponds to. <i>Displayed</i> corresponds to gross while viewing the gross weight and net otherwise.	Gross*, Net, Displayed
P173.--	<i>AnIFS</i>	Full scale value at which P172 selection yields an output of 10 volts. If set to 0, uses P110 setting.	Numeric Entry: 0* to ±1,000,000
P174.--	<i>AnOff</i>	Offset value which yields a 0 volt output.	Numeric Entry: 0* to ±1,000,000
P175.10	<i>AnRng</i>	Range Value (1-10) which specifies the max value of analog output – entered in terms of voltage. NOTE: This does not change the analog span. A 0-10,000 lb. output set to 8 will stop increasing its analog signal at 8,000 lbs.	Numeric entry: 0 to 10*
P176.01	<i>AnRst</i>	Reset state – Specifies analog signal level when Model 350 and Model 355 enters Setup Mode.	10 V (Max Output) 0 V (Min Output) No Change*
P177.00	<i>AType</i>	Specifies output type: voltage or current.	0 –10 volts*, 0 -20mA, 4 -20mA

$$V_{out} = \left(\frac{(P172: Parm Value) - (P174: Zero Offset)}{(P173: Full Scale Value) - (P174: Zero Offset)} \right) * 10$$

The actual output signal is calculated as follows:

If the result is greater than the Max Range Value (P175), then the analog signal is limited to the Max Range Value.

Analog Output Calibration



This section requires firmware rev 010 or later.

Table 16: Analog Output Calibration Parameters

PARAMETER SETTING	DISPLAYED NAME	DESCRIPTION	TYPE/CHOICES (*=DEFAULT)
P61200	<i>10oFF</i>	Value required to precisely output 0V in 0 – 10V output mode (i.e. offset).	Numeric Entry: 0 to 15,000 2,923*
P61201	<i>10Gn</i>	Value required to precisely output 10V in 0 – 10V output mode (i.e. gain).	Numeric Entry: 50,000 to 65,535 61,027*
P61202	<i>0oFF</i>	Value required to precisely output 0 mA in 0 – 20 mA output mode (i.e. offset).	Not adjustable: 0*
P61203	<i>0Gn</i>	Value required to precisely output 20 mA in 0 – 20mA output mode (i.e. gain).	Numeric Entry: 50,000 to 65,535 54,555*
P61204	<i>4oFF</i>	Value required to precisely output 0 mA in 4 – 20 mA output mode (i.e. offset).	Numeric Entry: 0 to 15,000 10,910*
P61205	<i>4Gn</i>	Value required to precisely output 20 mA in 4 – 20mA output mode (i.e. gain).	Numeric Entry: 50,000 to 65,535 54,555*
P61206	<i>Srln</i>	Analog option board serial number.	Numeric Entry: 0* - 4,294,967,295

The analog output calibration procedure establishes explicit zero and full scale values for each of the three analog output modes: 0 – 10V, 0 – 20 mA and 4- 20 mA. There are five adjustment values for the analog option, located at the information parameters P61200 through P61205, that allow the zero and full scale output of each mode to be adjusted to exact values. This allows the analog option to be configured to match the needs of the system being connected to its outputs.

The calibration values for each of these modes has been determined at the factory. These values are provided on paper with each board to make calibrating the analog option a simple process. Each analog option board can be identified by its serial number, which is entered in the unit during the calibration process.

ENTERING ANALOG CALIBRATION VALUES

An example of the printout included with each analog option kit follows below:

```

100s23640%i%e           Access Setup Modes, Allowing Changes

60100%s%e               P60100.  c1998-GSE-
60101%s%e               P60101.  0350p01009
60102%s%e               P60102.  06-30-2000

60200%s%e               P60200.  BrdSn573192
60201%s%e               P60201.  AuditTrail Euro  00001
60202%s%e               P60202.  InsSn329074
60203%s%e               P60203.  AuditTrail Cal.  00025
60204%s%e               P60204.  AuditTrail Setup 00050



61200%s2923%e          P61200.  10off  2923
61201%s61027%e         P61201.  10 Gn  61027
    
```





```

61202%s0%c          P61202.  0  off      0
61203%s54555%e     P61203.  0  Gn   54555
61204%s10910%e     P61204.  4  off  10910
61205%s54555%e     P61205.  4  Gn   54555
61206%s123456%e    P61206.  Sr1 n 123456

```

```
%z          Exit Setup Mode
```

Analog calibration values can be entered into the Model 350/355 by keying in the data in the left-hand column, beginning at the line starting with “61200...”, replacing the “%s” character pairs with the  key and “%e” with the  key. The line with the “%c” is not adjustable and thus not enterable.

You can adjust the included factory recommended offset and gain values to precisely configure the system being connected to these outputs. Once the initial factory values have been entered, pressing the  key will cause the count value to increase one count, and pressing the  +  or   keys will decrement the count value by one count. All changes made are updated “live” to aid in calibrating a specific device to the analog option board output. Holding down the key(s) will repeat the increment/decrement action.

ANALOG OUTPUT EXAMPLE

Analog Parameter Setting	Parameter Description	Example Value	Comments
P172.01	Net Weight	3.00 lb	Current net weight.
P173.--	Analog Full Scale	20	Net weight value that would give maximum analog output.
P174.--	Zero Offset	-40	Net weight value that would give minimum analog output.
P175.--	Max Range Value	8	Maximum analog output allowed (entered in terms of voltage).

$$V_{out} = \left(\frac{3 - (-40)}{20 - (-40)} \right) * 10 = \left(\frac{43}{60} \right) * 10 = 7.166$$

Since 7.166 v is less than 8 v (per P175), the output signal is not restricted and would be 7.166 v.

If a current output is selected, the output is a milli-amp current where 0 volts corresponds to either 0 mA or 4 mA (as per P177) and 10 volts would translate to 20 mA. Values in between would be scaled proportionately:

$$I_{out} = \left(\frac{(20 \text{ mA} - 4 \text{ mA}) * 7.166 \text{ v}}{10 \text{ v}} \right) + 4 \text{ mA} = \left(\frac{16 * 7.166}{10} \right) + 4 = 15.465 \text{ mA}$$

Analog signal resolution: the output is the result of a 16 bit conversion resulting in a resolution of 1 part in 65535 or 10 / 65535 = 0.00015 v.

Setpoint Setup

The Model 350/355 has several pre-programmed scale setpoint applications available at P5100. Various related setpoint parameters may appear according to which of the standard programs is chosen. Table 17 describes the available setpoint operations.

Table 17: Setpoint Operations

Setpoint Selection	Function	Description	Page Ref
P5100.00	<i>None</i>	Setpoints disabled.	
P5100.01	<i>ChecP</i>	Percentage check-weighing. Over/Under tolerances are based on a percentage of the target weight.	79
P5100.02	<i>Fill</i>	Single Ingredient Fill (Single or Dual-Speed). Allows the use of pre-acts for dribble feed and compensation for free-fall material. Includes a selectable 'learn' mode.	68
P5100.03	<i>Batch</i>	Batch up to three ingredients. Allows for the use of pre-acts to compensate for free-fall material. Includes selectable 'learn' modes.	69
P5100.04	<i>Dschg</i>	Single Ingredient Discharge (Single or Dual-Speed). Allows the use of pre-acts for dribble feed and compensation for free-fall material. Includes a selectable 'learn' mode.	71
P5100.05	<i>Both</i>	Single Ingredient Fill and Discharge. Fill large holding vessels and discharge material in pre-determined amounts. Allows for the use of pre-acts to compensate for free-fall material. Includes a selectable 'learn' mode.	73
P5100.06	<i>ChecA</i>	Absolute check-weighing. Over/Under tolerances are based on discrete values.	81
P5100.07	<i>Indep</i>	Independent Setpoints. Activation based on specific target values. Includes selectable reset conditions.	75

Each program utilizes the three annunciators located to the left of the main display to give a visual status of the setpoint. A setpoint option board may be installed to allow control of an external device (see *Setpoint Card Connections* on page 26).

ACTIVATION METHODS (GENERAL)

Setpoint activation for Fill, Batch, Discharge, and Both can be initiated in one of three ways: Tare, Remote or Auto. Check-weigh operations have no start function. Independent setpoint operations are limited to Above or Below activation. The Model 350 IS and Model 355 IS setpoint option board may be connected in-series with a larger automated control system or a manually activated switching device. A foot switch, a two-hand safety station, or other permissive-start devices may be used for safety or system compatibility.

Activation Method	Description
Tare Operation	 activates the setpoint. It waits for a no-motion condition, then tares scale to net zero. The appropriate setpoint is then activated.
Remote Key	The [REMOTE KEY] closure activates the setpoint. The remote key function (assigned at P800) is <i>over-ridden</i> .
Auto-Start	Automatically activates the setpoint. It waits for a no-motion condition, then adds the target to the current displayed weight to achieve a <i>relative</i> cutoff value.

PRE-ACTS (GENERAL)

Pre-Acts are control actions prior to reaching a desired target value. Necessary to prevent over-filling due to product flow rate, relay and valve response time and product suspension, Pre-Acts and other system variables affect how much *more* product reaches the weighing device after the indicator has deactivated a setpoint.

Pre-act 1

Used in dual-speed applications, pre-act 1 specifies when the 350/355 should switch from fast-fill to slow-fill, allowing the system to perform the bulk of a filling operation as quickly as possible before switching to a more manageable dribble mode for final cutoff. When using a single-speed device, set pre-act 1 to 0.

Pre-act 2

Specifies the weight where the final cutoff should occur, enabling the 350/355 to compensate for a dispensing control's closure time and account for free-fall material. Free-fall is the amount of product that has passed the point of the dispensing control yet not yet reached the weighing device.

Pre-act values are entered in terms of the amount of product that would over-fill or 'how early' to close the control device. For instance, after repeated tests, a system consistently over-fills by .5 lbs. This is the value that should be entered as the pre-act. The 350/355 would then deactivate the setpoint .5 lbs. less than the desired final target value.

Parameter Setting	Actual Cutoff Value	Comments
Target = 400 lbs.		Desired final weight.
Pre-Act 1 = 28	$400 - 28 = 372$	Switch to slow feed at 372 lbs.
Pre-Act 2 = .5	$400 - 0.5 = 399.5$	Final fill valve closes at 399.5 lbs.

LEARN FEATURE (GENERAL)

The 350/355 can 'learn' optimal pre-act values. When enabled, the learn feature will automatically adjust the final cutoff value based on an analysis of the five previous fills, helping achieve a final target by compensating for product viscosity, changes in plant air pressures, sticky valves, etc. For each cycle, the prior five final weights are analyzed and a new pre-act value is calculated.

PAUSE FEATURE (GENERAL)



The 350/355 can pause setpoint operations. This is useful as a safety device, for mid-cycle operator breaks, mechanical adjustments, etc.





When invoked, Pause deactivates all setpoints. The display will show: *Tare= ~ Abort*. Pressing  will abort the current cycle; any other keypress will resume the cycle. The Pause feature has four settings:

Pause Setting	Action	Result
Disabled		Pause feature disabled.
Keypad	350/355 Key Press	Current cycle paused – all setpoints deactivated.
Remote Key	Remote Key Contact Closure	Current cycle paused – all setpoints deactivated.
Both	350/355 Key Press OR Remote Key Contact Closure	Current cycle paused – all setpoints deactivated.

CHANGING TARGETS FROM THE WEIGH MODE (GENERAL)

When a setpoint operation is configured from the Setup Mode, certain parameters are made available in the Weigh Mode. Pressing  cycles through available modes (Gross, Net, Quantity, Targ 1, etc.).

When viewing a setpoint-related parameter from the Weigh Mode,  takes on a special function. Data keyed in prior to  will be displayed as the new setpoint parameter value. Pressing  alone will advance to the first *subset* for the current setpoint parameter. Pre-acts and tolerances are subsets of their respective target values.













A negative target value may be entered for the independent setpoints only. To enter the negative sign press  then  +  (Model 350 IS) or  (Model 355 IS). A negative sign will be displayed. Press  to continue with the entry

Programs that involve a discharge cycle are loss-in-weight type applications. Any target or pre-act values for these programs should be entered as *positive* numbers. The 350/355 will automatically interpret these values as negative.

EXAMPLE (GENERAL)

The target for the fill setpoint operation is Targ 1. This is a setpoint-related parameter and automatically becomes an available mode when Fill is configured in the setpoint setup. Pre-act 1 and pre-act 2 are *subsets* of Targ 1. The following procedure illustrates how to change a target from 250 lbs to 400 lbs., keep pre-act 1 at 28 lbs. and change pre-act 2 from 1.5 lbs to .5 lbs.

To change targets from the Weigh Mode (350 IS):

1. Press .
DISPLAY READS ►0.00
2. Press  to view the current fill target.
DISPLAY READS ►Targ1 ~ 250
3. Press   to set a new fill target of 400 lbs.
DISPLAY READS ►Targ1 ~ 400
4. Press  to select the Pre-Act 1 (subset) value of 28 lbs.
DISPLAY READS ►PA 1 ~ 28
5. Press  to select the Pre-Act 2 (subset) value of 1.5 lbs.
DISPLAY READS ►PA 2 ~ 1.5
6. Press   to select a new Pre-Act 2 value of .5 lbs.
DISPLAY READS ►PA 2 ~ .5
7. Press  to display the current Gross Weight.
DISPLAY READS ►15.12

To change targets from the Weigh Mode (355 IS):

1. Press ON
TARGET.
DISPLAY READS ►0.00
2. Press SELECT to view the current fill target.
DISPLAY READS ►Targ1 ~ 250

BARGRAPH (GENERAL)

A bargraph display is available for the ChecP, Fill, Batch, Dschg, Both and ChecA setpoint modes of operation. To enable the bargraph, refer to parameter P5011 (SPbar) in the *Parameter Map* section beginning on page 47. To weight each segment of the bargraph refer to parameter P5012 (bArPc) in the *Parameter Map* section beginning on page 47.

SCALING FOR “BARS” (BARGRAPH ARROWS)

If the first bar turns off at the specified percentage (set at P5012) of the low limit, and the last bar turns off at the low limit, then the difference will be divided by 8 to determine the number of lbs per bar. At less than 5 grads, the entire graph is off.

Example#1: “ChecP” (refer to Figure 30)

-)
- Lower Limit is set at 50lbs.
- **P5012** is set for **80%**
- **(Bar weight = 50 – 40 = 10)**
(10/8 = 1.25 lbs)

NOTE: Right-side bars will have the same scaling (lb per bar) as the left-side bars. They are represented as a mirror image of each other.

<u>Bars ON</u>	<u>Weight Range (Lower Tolerance Limit)</u>
9	< 40
8	40.00 to 41.25
7	41.25 to 42.50
6	42.50 to 43.75
5	43.75 to 45.00
4	45.00 to 46.25
3	46.25 to 47.50
2	47.50 to 48.75
1	48.75 to 50.00

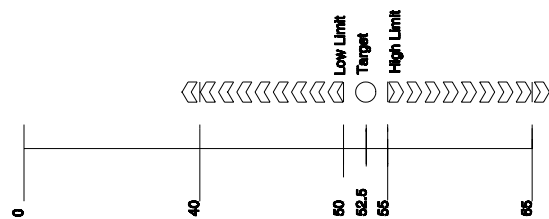

Figure 30: Example #1 Bargraph Segments (Weighted Value)

Example#2: : “ChecP” (refer to Figure 31)

- Lower Limit is set at 50lbs.
- **P5012** is set for **20%**
- **(Bar weight = 50 – 10 = 40)**
(40/8 = 5 lbs)

NOTE: Right-side bars will have the same scaling (lb per bar) as the left-side bars. They are represented as a mirror image of each other.

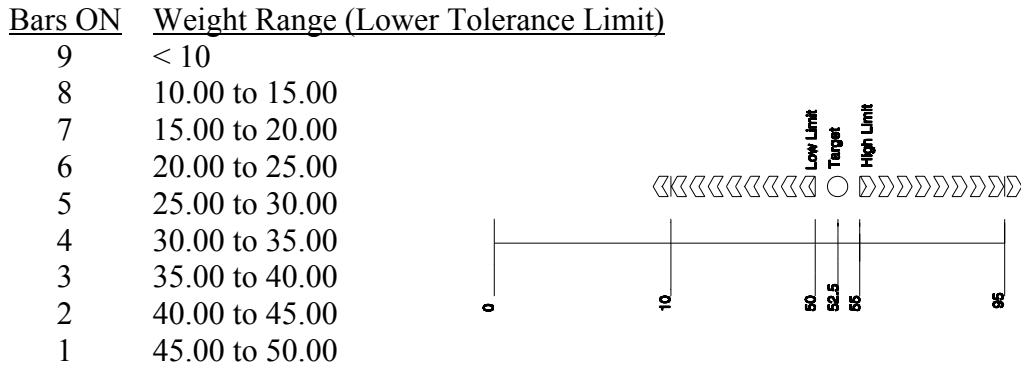

Figure 31: Example #2 Bargraph Segments (Weighted Value)

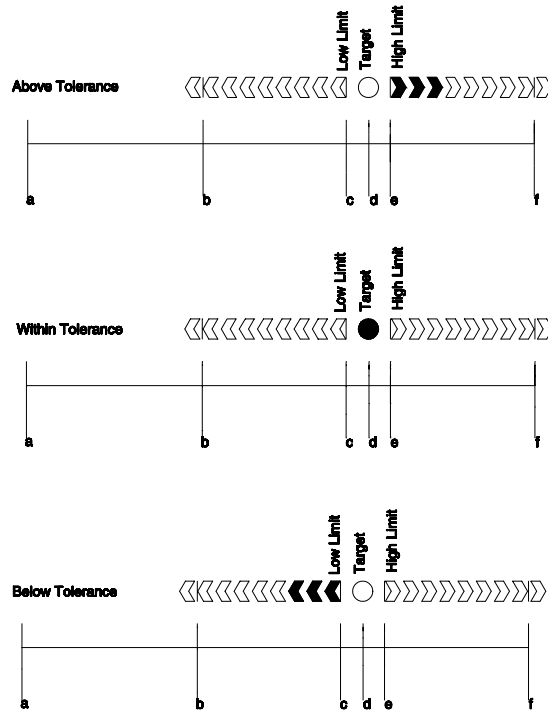

Figure 32: Examples of the Bargraph "Below, Within and Above Tolerance"

NOTE: (bargraph for filling and emptying modes)

For modes other than check-weighing, the bars will be on *only* while the setpoints are on and during the "Done" at the end of a fill.

The bar weights will be calculated similar to the check-weigh modes of operation stated above for filling, batching, etc., except that the percentage will be based on the actual target, rather than the low-limit value (see the equation below). The operation for emptying (and the emptying portion of 'both') will be the same except that the weight will be going negative while the left side bars are turning off.

$$\text{Target} - \left[\frac{(\% \text{ set at P5012}) \cdot \text{Target}}{100} \right]$$

$$\text{Bargraph segment weight} = \frac{100}{8.5}$$



Although the setpoint annunciators are not motion-inhibited, the setpoint relay outputs will not activate until a no-motion condition exists.

Fill

The fill program is used for single-speed or dual-speed filling operations. The dual-speed fill operation allows for both a fast and a slow fill mode. During a fast-fill, setpoints 1 and 2 are activated. During a slow-fill or single-speed fill, only setpoint 1 is activated.

Table 18: Setpoint Setup (Fill)

Setpoint Selection	Function	Description
P5100.1	Fill	Select Fill Setpoint Operation
P5101.--	Targ1	Final Fill Target Value
P5104.0	Based	Select between Net or Quantity
P5105.--	PA 1	Pre-Act 1 Value (Fast-to-Slow Value; 0 for Single-Speed)
P5107.0	Start 1	Setpoint Activation Method
P5109.--	PA 2	Pre-Act 2 Value (Final Cutoff)
P5110.1	Learn 2	Learn Feature for Pre-Act 2
P5114.1	PrAc 1	Pre-Act 1 Available as Subset in Weigh Mode
P5115.1	PrAc 2	Pre-Act 2 Available as Subset in Weigh Mode
P5116.1	Pause	Keypad Press invokes Pause

See *Key-In Parameters* on page 43 for instructions on using front panel keys for entering data.

ACTIVATION METHOD (FILL)

The fill begins with the selected activation method. The deactivation of the setpoints is automatic. The desired target may be based on net or quantity (if counting is enabled). See *Activation Methods (General)* on page 63 for activation details.

Fill Status	Annunciator Status	Setpoint Status (Requires Setpoint Option Board)
Fast Fill	SP 1 & SP 2 Illuminated	Relay 1 and Relay 2 Contacts Closed
Dribble Fill (or Single-Speed Fill)	SP 1 Illuminated	Relay 1 Contacts Closed
Fill Done or Pause	SP 1 & SP 2 Off	Relay 1 and Relay 2 Contacts Open

PRE-ACTS (FILL)

Pre-act 1 is used for dual-speed filling. Pre-act 1 specifies when the M350 should switch from fast-fill to slow-fill. When using a single-speed device, pre-act 1 should be set to 0 from the Setup Mode. P5114 should also be disabled to prevent pre-act 1 from appearing as a subset of target in the Weigh Mode.

Pre-act 2 specifies the target where the final cutoff should occur, regardless of a single-speed or dual-speed operation.



Pre-act 1 controls setpoint 2. Pre-act 2 controls setpoint 1.

See *Pre-acts (General)* on page 64 for details on the operational functions of pre-acts.

LEARN FEATURE (FILL)





Pre-act 2 has a learn feature available which allows the indicator to adjust the final cutoff based on changing environmental conditions. See *Learn Feature (General)* on page 64 for 'learn' feature details.

PAUSE FEATURE (FILL)

The standard pause feature (keypress, remote key closure or both) is available for the fill operation. See *Pause Feature (General)* on page 64 for 'pause' function details.

CHANGING TARGETS FROM THE WEIGH MODE (FILL)

When Discharge is configured in the setpoint setup, Targ 1 automatically becomes an available mode for the  key.

An entry followed by  or  changes Targ 1. Pressing  or  alone allows access to the subsets. PA 1 and PA 2 are the subsets for Targ 1. The pre-acts can be deleted as subsets by choosing 'disabled' at P5114 and P5115. See *Changing Targets from the Weigh Mode (General)* on page 65 for instructions on changing target values from the Weigh Mode.

EXAMPLE (FILL)

With a system set up to fill 55-gallon drums with motor oil, the following settings might be used to achieve an accurate final fill weight of 400 lbs.:

Parameter Setting	Actual Cutoff Value	Comments
Targ 1 = 400		Desired final weight.
Pre-act 1 = 28	$400 - 28 = 372.0$	Switch to dribble feed at 372.
Pre-act 2 = .5	$400 - 0.5 = 399.5$	Final fill valve closes at 399.5.

Batch

The standard batch program is used for batching up to three separate items. Ingredients 1 through 3 use setpoints and pre-acts 1 through 3 respectively. Ingredients are batched one at a time.

Table 19: Setpoint Setup (Batch)

Setpoint Selection	Function	Description
P5100.3	Batch	2 or 3 ingredient batching.
P5101.--	Targ1	Ingredient 1 target value.
P5104.0	Based	Select from <i>net</i> or <i>count (quantity)</i> .
P5105.--	PA 1	Pre-act 1 value (final cutoff for ingredient 1).
P5106.1	Learn 1	Learn feature for pre-act 1 enabled.

Setpoint Selection	Function	Description
P5107.0	Start 1	Setpoint 1 activation method.
P5108.--	Targ 2	Ingredient 2 target value.
P5109.--	PA 2	Pre-act 2 value (final cutoff for ingredient 2).
P5110.1	Learn 2	Learn feature for pre-act 2 enabled.
P5111.0	Start 2	Setpoint 2 activation method.
P5116.1	Pause	Keypad press invokes pause mode.
P5117.--	Targ 3	Ingredient 3 target value.
P5118.--	PrAc 3	Pre-act 3 value (final cutoff for ingredient 3).
P5119.1	Learn 3	Learn feature for pre-act 3 enabled.
P5120.0	Start 3	Setpoint 3 activation method.

See *Key-In Parameters* on page 43 for instructions on using front panel keys for entering data.

ACTIVATION METHOD (BATCH)

The filling of each ingredient begins when one of three selectable start functions occur. Each ingredient may have its own start function. The deactivation of the setpoint is automatic. The desired targets may be based on net weight or quantity (if counting is enabled). All ingredients must be based on the same parameter. See *Activation Methods (General)* on page 63 for details on activation methods.

Batch Status	Annunciator Status	Setpoint Status (Requires Setpoint Option Board)
Fill 1	SP 1 Illuminated	Relay 1 Contacts Closed, Relay 2 and 3 Contacts Open
Fill 2	SP 2 Illuminated	Relay 2 Contacts Closed, Relay 1 and 3 Contacts Open
Fill 3	SP 3 Illuminated	Relay 3 Contacts Closed, Relay 1 and 2 Contacts Open

PRE-ACTS (BATCH)

Pre-acts 1, 2 and 3 specify the final cutoff for each respective ingredient. See *Per-acts (General)* on page 64 for pre-act details.

LEARN FEATURE (BATCH)





Each batch pre-act has the learn feature available which allows the indicator to automatically adjust the final cutoff based on changing environmental conditions. See *Learn Feature (General)* on page 64 for 'learn' feature details.

PAUSE FEATURE (BATCH)

The standard pause feature (keypress, remote key closure or both) is available for the batch operation. See *Pause Feature (General)* on page 64 for 'pause' details.

CHANGING TARGETS FROM THE WEIGH MODE (BATCH)

When Discharge is configured in the setpoint setup, Targ 1 automatically becomes an available mode for the  key.

An entry followed by  or  changes Targ 1. Pressing  or  alone allows access to the subsets. PA 1 and

PA 2 are the subsets for Targ 1. The pre-acts can be deleted as subsets by choosing ‘disabled’ at P5114 and P5115. See *Changing Targets from the Weigh Mode (General)* on page 65 for instructions on changing target values from the Weigh Mode.



Pre-acts 1 and 2 are *always* available as subsets of their respective targets from the Weigh Mode.

EXAMPLE (BATCH)

With a system set up a system to make a 50,000 lb batch with water (30,000 lbs.), corn syrup (15,000 lbs.) and caramel color (5,000 lbs.), ingredient 1 should start with  and subsequent ingredients should auto-start.

Parameter Setting	Actual Cutoff Value	Comments
Target 1 = 30,000		Desired water weight.
Based = Net		Targets are compared to net weight.
Pre-Act 1 = 100	$30,000 - 100 = 29,900$	Water valve closes at 29,900 lbs. Free-fall will bring weight to 30,000.
Learn 1 = Enabled		Analyze previous five fills and auto-adjust pre-act 1.
Start 1 = Tare		Start water with  .
Target 2 = 15,000		Desired corn syrup weight.
Pre-Act 2 = 236	$15,000 - 236 = 14,764$	Corn syrup valve closes at 14,764 lbs. Free-fall will bring weight to 15,000.
Learn 2 = Enabled		Analyze previous five fills and auto-adjust pre-act 2.
Start 2 = Auto	Calculated cutoff value for corn syrup is added to current displayed weight	Start corn syrup when water is done and motion has stopped.
Target 3 = 5,000		Desired caramel coloring weight.
Pre-Act 3 = 142	$5,000 - 142 = 4,858$	Carmel coloring valve closes at 4,858. Free-fall will bring weight to 5,000.
Learn 3 = Enabled		Analyze previous five fills and auto-adjust pre-act 3.
Start 3 = Auto	Calculated cutoff value for carmel coloring is added to current displayed weight	Start caramel coloring when corn syrup is done and motion has ceased.
Pause = Keypad		Keypress will pause batch operation.

Discharge

The discharge program is designed for single-speed or dual-speed dispensing of product from a larger weigh vessel. Discharge is a loss-in-weight application similar in operation to the fill program. When a discharge is initiated, the scale automatically tares and comes to a net zero weight. The appropriate setpoints are activated and material is discharged until the decreasing net weight reaches the desired target value.

Table 20: Setpoint Setup (Discharge)

Setpoint Selection	Function	Description
P5100.1	Discharge	Select discharge setpoint operation.
P5101.--	Targ1	Final dispensed target value.
P5104.0	Based	Select between net or count (quantity)
P5105.--	PA 1	Pre-act 1 value (fast-to-slow value; 0 for single-speed).
P5107.0	Start 1	Setpoint activation method.
P5109.--	PA 2	Pre-act 2 value (final cutoff).
P5110.1	Learn 2	Learn feature for pre-act 2.
P5114.1	PrAc 1	Pre-act 1 available as subset in Weigh Mode.
P5115.1	PrAc 2	Pre-act 2 available as subset in Weigh Mode.
P5116.1	Pause	Keypress invokes pause.

See *Key-In Parameters* on page 43 for instructions on using front panel keys for entering data.

ACTIVATION METHOD (DISCHARGE)

The dispensing activation is limited to  or a remote key input. The deactivation of the setpoints is automatic. The desired target may be based on net or quantity (if counting is enabled). See *Activation Methods (General)* on page 63 for activation details.

Discharge Status	Annunciator Status	Setpoint Status (Requires Setpoint Option Board)
Fast Discharge	SP 1 & SP 2 Illuminated	Relay 1 and 2 Contacts Closed
Slow (or Single-Speed) Discharge	SP 1 Illuminated	Relay 1 Contacts Closed
Fill Done or Pause	SP 1 & 2 Off	Relay 1 and 2 Contacts Open

PRE-ACTS (DISCHARGE)

Pre-act 1 is used for dual-speed dispensing. Pre-act 1 specifies when the system should switch from fast-discharge to slow-discharge. When using a single-speed device, pre-act 1 should be set to 0 from the Setup Mode. P5114 should also be disabled to prevent pre-act 1 from appearing as a subset of the target in the Weigh Mode. Pre-act 2 specifies the point where the final cutoff should occur, regardless of a single-speed or dual-speed operation. See *Pre-acts (General)* on page 64 for details on the operational functions of pre-acts.



Pre-act 1 controls setpoint 2. Pre-act 2 controls setpoint 1.

LEARN FEATURE (DISCHARGE)





Pre-act 2 has the learn feature available which allows the indicator to automatically adjust the final cutoff based on changing environmental conditions. See *Learn Feature (General)* on page 64 for learn feature details.

PAUSE FEATURE (DISCHARGE)

The standard pause feature (keypress, remote key closure or both) is available for the discharge operation. See *Pause Feature (General)* on page 64 for pause function details.

TARGET CHANGES FROM THE WEIGH MODE (DISCHARGE)

When Discharge is configured in the setpoint setup, Targ 1 automatically becomes an available mode for the  key.

An entry followed by  or  changes Targ 1. Pressing  or  alone allows access to the subsets. PA 1 and PA 2 are the subsets for Targ 1. The pre-acts can be deleted as subsets by choosing ‘disabled’ at P5114 and P5115. See *Changing Targets from the Weigh Mode (General)* on page 65 for instructions on changing target values from the Weigh Mode.





Target and pre-act values are entered as positive values.

If the total amount of product in the weigh vessel is less than the entered target, the indicator will prompt **Tare ~** =**Cont**. Pressing  will dispense whatever is left in the vessel. Pressing any other key will abort the discharge cycle to allow for refilling the vessel.

EXAMPLE (DISCHARGE)

With a system set up to dispense ball bearings from a 50,000 lb weigh-bin and the fast-feed requiring an early cutoff to slow-feed, the following settings might be used to achieve accurate dispensing of 1000 bearings:

Parameter Setting	Actual Cutoff Value	Comments
Targ 1 = 1000	0 – 1000 = (-1000)	Desired quantity (decreasing value from a net zero: enter as a positive value).
Based = Qty		Targets are compared to quantity (P170 Enabled).
PA 1 = 200	1000 – 200 = 800 0 – 800 = (-800)	Switch to slow feed at –800 bearings (decreasing value from a net zero: enter as a positive value).
Start = 		Start discharge with  .
PA 2 = 15	1000 – 15 = 985 0 – 985 = (-985)	Final gate begins closing at 985 bearings. Delayed closure brings final quantity to 1000 (decreasing value from a net zero: enter as a positive value).
Learn 2 = Enabled		Analyze five previous operations and auto-adjust Pre-Act 2.
PrAc 1 = Enabled		Pre-act 1 available as subset of Targ 1 in Weigh Mode.
PrAc 2 = Disabled		Pre-act 2 NOT available as subset of Targ 1 in Weigh Mode (auto-adjust only).
Pause – Remote		Remote key closure invokes Pause.

Both

The ‘Both’ program combines a fill operation with a discharge operation. This automates a single-speed vessel filling operation with a single-speed multiple dispensing function. Setpoint 1 is used for filling the vessel and Setpoint 2 is used for product discharge. The ‘both’ program uses values for two targets and two pre-acts. Both targets must be based alike (net or quantity, quantity if count is selected).

Table 21: Setpoint Setup (Both)

Setpoint Selection	Function	Description
P5100.5	Both	Select both setpoint operation.
P5101.--	Targ1	Vessel fill target value.
P5104.0	Based	Select from <i>Net</i> or <i>Count (Quantity)</i> .

Setpoint Selection	Function	Description
P5105.--	PA 1	Pre-act 1 value for vessel fill.
P5106.1	Learn 1	Learn feature for pre-act 1.
P5107.0	Start 1	Setpoint 1 activation method.
P5108.--	Targ 2	Vessel discharge target value.
P5109.--	PA 2	Pre-act 2 value for vessel discharge.
P5110.1	Learn 2	Learn feature for pre-act 2.
P5111.0	Start 2	Setpoint 2 activation method.
P5116.1	Pause	Keypad press invokes pause.

See *Key-In Parameters* on page 43 for instructions on using front panel keys for entering data.

ACTIVATION METHOD (BOTH)

The fill and discharge functions begin with their selected activation methods. The deactivation of the setpoints is automatic. The desired target may be based on net or quantity (if counting is enabled). See *Activation Methods (General)* on page 63 for activation details.

Both Status	Annunciator Status	Setpoint Status (Requires Setpoint Option Board)
Vessel Fill	SP 1 Illuminated	Relay 1 Contacts Closed
Vessel Discharge	SP 2 Illuminated	Relay 2 Contacts Closed
Fill Done or Pause	SP 1 & SP 2 Off	Relay 1 and Relay 2 Contacts Open

PRE-ACTS (BOTH)

Pre-act 1 is used for vessel filling. Pre-act 1 specifies the point where the final cutoff for the fill should occur. Pre-act 2 specifies the point where the final cutoff for the material discharge should occur. See *Pre-acts (General)* on page 64 for details on the operational functions of pre-acts.



Pre-act 1 controls setpoint 1. Pre-act 2 controls setpoint 2.





LEARN FEATURE (BOTH)

Both pre-act 1 and 2 have the learn feature available which allows the indicator to automatically adjust the final cutoff based on changing environmental conditions. See *Learn Feature (General)* on page 64 for 'learn' feature details.

PAUSE FEATURE (BOTH)

The standard pause feature (keypress, remote key closure or both) is available for the Both operation. See *Pause Feature (General)* on page 64 for 'pause' functions details.

TARGET CHANGES FROM THE WEIGH MODE (BOTH)

When Both is configured in the setpoint setup, Targ 1 and Targ 2 automatically become available modes for the  key. An entry followed by  or  changes the currently viewed target. Pressing  or  alone allows access to the subsets. PA 1 is the subset for Targ 1 and PA 2 is the subset for Targ 2.



Pre-acts 1 and 2 are always available as subsets of their respective targets from the Weigh Mode.

Since the discharge portion of the Both cycle is a loss-in-weight operation, target 2 and pre-act 2 entries are entered as positive values and interpreted by the indicator as negative. See *Changing Targets from the Weigh Mode (General)* on page 65 for detailed instructions on changing target values from the Weigh Mode.

EXAMPLE (BOTH)

With a system set up to fill a weigh vessel with 2000 lbs. of paint and to meter out the paint in 45 lb buckets, the following settings might be used:

Parameter Setting	Actual Cutoff Value	Comments
Targ 1 = 2000		Desired vessel fill target.
Based = Net		Targets are compared to net weight.
PA 1 = 5	$2000 - 5 = 1995$	Fill valve closes at 1995 lbs.
Learn 1 = Enabled		Analyze five previous fills and auto-adjust pre-act 1.
Start 1 = R-but		Start fill with remote key closure.
Targ 2 = 45	$0 - 45 = (-45)$	Desired discharge target (decreasing weight from a net zero: enter as a positive value).
PA 2 = 5	$45 - 5 = 40$ $0 - 40 = (-40)$	Discharge valve closes at (-40) lbs. (decreasing weight from a net zero: enter as a positive value).
Learn 2 = Enabled		Analyze five previous discharges and auto-adjust pre-act 2.
Start 2 =		Start discharge with .
Pause = None		Disable pause function.

Independent Setpoint Operation

Independent Setpoints allow controlling setpoints when the gross, net or quantity (if counting is enabled) is above or below a target value. The reset (deactivation) choice of each setpoint is selectable from *Tare, Remote Key, Auto, Non-latching* or *Absolute*. See *Key-In Parameters* on page 43 for instructions on using front panel keys for data entry.

Table 22: Setpoint Setup (Independent)

Setpoint Selection	Function	Description
P5100.7	Indep	Independent Setpoints.
P5121.1	Base 1	Select from <i>Net, Gross</i> or <i>Count (Quantity)</i> for setpoint 1.
P5122.0	Act 1	Activate setpoint 1 when weight is above or below.
P5123.--	Targ 1	Setpoint 1 target for weight to either rise above or fall below.
P5124.0	Stbl 1	Setpoint 1 activation stability setting.
P5125.0	Rset 1	Reset selection for setpoint 1.
P5126.--	Rtrg 1	Value for reset. *Only available if "Value" is selected for Reset 1.
P5127.1	Rstb 1	Reset 1 stability setting.
P5131.1	Base 2	Select from <i>Net, Gross</i> or <i>Count (Quantity)</i> for Setpoint 2.
P5132.0	Act 2	Activate setpoint 2 when weight is above or below.
P5133.--	Targ 2	Setpoint 2 target for weight to either rise above or fall below.
P5134.0	Stbl 2	Setpoint 2 stability setting.
P5135.0	Rset 2	Reset selection for setpoint 2.
P5136.--	Rtrg 2	Value for reset. *Only available if "Value" is selected for Reset 2.

Setpoint Selection	Function	Description
P5137.1	Rstb 2	Reset 2 stability setting.
P5141.1	Base 3	Select from <i>Net</i> , <i>Gross</i> or <i>Count (Quantity)</i> for Setpoint 3.
P5142.0	Act 3	Activate setpoint 3 when weight is above or below.
P5143.--	Targ 3	Setpoint 3 target for weight to either rise above or fall below.
P5144.0	Stbl 3	Setpoint 3 stability setting.
P5145.0	Rset 3	Reset selection for setpoint 3.
P5146.--	Rtrg 3	Value for reset. *Only available if “Value” is selected for Reset 3.
P5147.1	Rstb 3	Reset 3 stability setting.

SETPOINT ACTIVATION (INDEPENDENT)

Independent Setpoints can be activated when either the gross weight, net weight or quantity (if counting is enabled) is above or below a target value. When an independent setpoint is set to Activate Above, the setpoint will activate when the selected mode (gross, net or quantity) is equal to or above the target. When set to Activate Below, the selected mode must actually be below the target.



A setpoint option board may be installed to allow the M350 to directly control lights, buzzers, valves or relays (see *Setpoint Card Connections* on page 26). Also, the setpoints can be configured to ignore or heed the stability setting (**P114**).

Independent Status	Annunciator Status	Setpoint Status (Requires Setpoint Option Board)
Setpoint 1 Active	SP 1 Illuminated	Relay 1 Closed
Setpoint 2 Active	SP 2 Illuminated	Relay 2 Closed
Setpoint 3 Active	SP 3 Illuminated	Relay 3 Closed

Independent Setpoint Reset (deactivation) choices:

Parameter Setting	Reset Choice	Description
P51x5.0	Tare	Setpoint deactivates with .
P51x5.1	Remote Key	Setpoint deactivates with Remote Key closure.
P51x5.2	Auto	Setpoint deactivates when weight returns to +/- 5 graduations of zero and stabilizes.
P51x5.3	Non-Latched	Setpoint deactivates when weight value is in a range opposite of the activation setting.
P51x5.4	Reset Value	Setpoint deactivates when weigh reaches a second value and stabilizes.



The Pre-Acts, Learn Mode, and Pause Feature options are not applicable to Independent Setpoint operation.

CHANGING TARGETS FROM THE WEIGH MODE (INDEPENDENT)

When Independent Setpoints are configured in the setpoint setup, Targ 1, 2 and 3 automatically become available modes for the key. An entry followed by or changes the currently viewed target. If the reset for a setpoint is set to ‘value’, then pressing or alone will allow access to the subset of the target. Rtrg 1, 2 and 3 are the respective subsets for Targ 1, 2 and 3. See *Changing Targets from the Weigh Mode (General)* on page 65 for detailed instructions on changing target values from the Weigh Mode.

EXAMPLE (INDEPENDENT)

Setup a continuous-cycle static weighing system that fills a weigh hopper from a storage bin. The weigh hopper should stop the fill at a predetermined target, dump the product into a bag, and then restart the fill. A warning light should come on to give an operator advance notice to change the bag. The following setup might be used to achieve 1000 lb dumps:

Parameter Setting	Description
<i>P5121.1 ~ Base 1 ~ Net</i>	Weigh hopper dump valve based on net weight.
<i>P5122.0 ~ Act 1 ~ HI</i>	Hopper dump valve opens when net weight rises above target 1.
<i>P5123.-- ~ Targ 1 ~ 1000</i>	Target 1 value = 1000 kg.
<i>P5124.1 ~ Stbl 1 ~ Inhib</i>	Hopper dump valve delayed until scale is stable.
<i>P5125.2 ~ Rset 1 ~ Auto</i>	Dump valve auto-closes when net is within +/- 5 grads of zero and stable.
<i>P5127.1 ~ Rstb1 ~ Inhib</i>	Dump valve closure delayed until scale is stable.
<i>P5131.1 ~ Base2 ~ Net</i>	Weigh hopper fill valve based on net weight.
<i>P5132.1 ~ Act 2 ~ Under</i>	Fill valve opens when net weight falls below target 2.
<i>P5133.-- ~ Targ 2 ~ =100</i>	Target 2 value = 100 kg.
<i>P5134.1 ~ Stbl2 ~ =Inhib</i>	Fill valve opening delayed until scale is stable.
<i>P5135.4 ~ Rset 2 ~ =Targ</i>	Fill valve closes when net weight reaches reset target 2.
<i>P5136.-- ~ Rtrg2 ~ 1000</i>	Reset target 2 = 1000 kg.
<i>P5137.0 ~ Rstb2 ~ Ignore</i>	Fill valve closes regardless of stability.
<i>P5141.1 ~ Base 3 ~ Net</i>	Alarm light relay based on net weight.
<i>P5142.0 ~ Act 3 ~ Above</i>	Alarm relay activates when net weight rises above target 3.
<i>P5143.-- ~ Targ 3 ~ =900</i>	Target 3 = 900 kg.
<i>P5144.0 ~ Stbl3 ~ Ignore</i>	Alarm relay activates regardless of scale stability.
<i>P5145.3 ~ Rset 3 ~ Non-L</i>	Alarm relay closes when net weight falls below target 3.
<i>P5147.0 ~ Rset3 ~ Ignore</i>	Alarm relay closes regardless of scale stability.

Bargraph Setup (LCD)

A bargraph display is available for the ChecP and ChecA setpoint modes of operation. To enable the bargraph, refer to parameter P5011 (SPbar) in the *Parameter Map* section beginning on page 52. To weight each segment of the bargraph refer to parameter P5012 (bArPc) in the *Parameter Map* section beginning on page53.

SCALING FOR “BARS” (BARGRAPH ARROWS)

If the first bar turns off at the specified percentage (set at P5012) of the low limit, and the last bar turns off at the low limit, then the difference will be divided by 8 to determine the number of lbs per bar. At less than 5 grads, the entire graph is off.

Example#1: “ChecP” (refer to

Figure 33

-)
- Lower Limit is set at 50lbs.
- **P5012** is set for **80%**
- **(Bar weight = 50 – 40 = 10)**
(10/8 = 1.25 lbs)

NOTE: Right-side bars will have the same scaling (lb per bar) as the left-side bars. They are represented as a mirror image of each other.

Bars ON Weight Range (Lower Tolerance Limit)
9 < 40

8	40.00 to 41.25
7	41.25 to 42.50
6	42.50 to 43.75
5	43.75 to 45.00
4	45.00 to 46.25
3	46.25 to 47.50
2	47.50 to 48.75
1	48.75 to 50.00

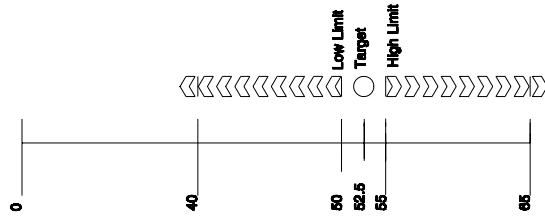

Figure 33: Example #1 Bargraph Segments (Weighted Value)

Example#2: “ChecP” (refer to Figure 34)

- Lower Limit is set at 50lbs.
- **P5012** is set for **20%**
- (**Bar weight** = 50 – 10 = 40)
(40/8 = **5 lbs**)

NOTE: Right-side bars will have the same scaling (lb per bar) as the left-side bars. They are represented as a mirror image of each other.

<u>Bars ON</u>	<u>Weight Range (Lower Tolerance Limit)</u>
9	< 10
8	10.00 to 15.00
7	15.00 to 20.00
6	20.00 to 25.00
5	25.00 to 30.00
4	30.00 to 35.00
3	35.00 to 40.00
2	40.00 to 45.00
1	45.00 to 50.00

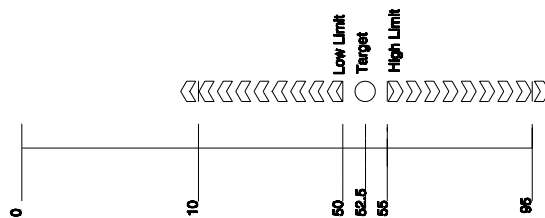

Figure 34: Example #2 Bargraph Segments (Weighted Value)

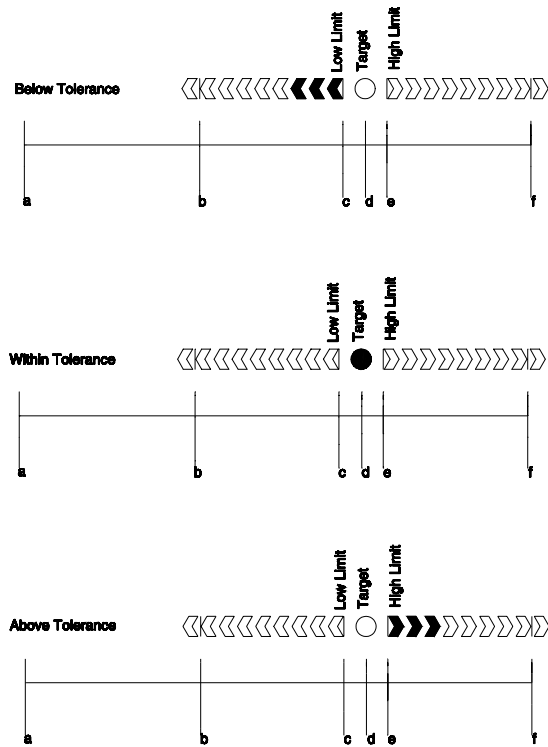

Figure 35: Examples of the Bargraph "Below, Within and Above Tolerance"

NOTE: (bargraph for filling and emptying modes)

For modes other than check-weighing, the bars will be on *only* while the setpoints are on and during the "Done" at the end of a fill.

The bar weights will be calculated similar to the check-weigh modes of operation stated above for filling, batching, etc., except that the percentage will be based on the actual target, rather than the low-limit value (see the equation below). The operation for emptying (and the emptying portion of 'both') will be the same except that the weight will be going negative while the left side bars are turning off.

$$\text{Bargraph segment weight} = \frac{\text{Target} - \left[\left(\frac{\% \text{ set at P5012}}{100} \cdot \text{Target} \right) \right]}{8.5}$$



Although the setpoint annunciators are not motion-inhibited, the setpoint relay outputs will not activate until a no-motion condition exists.

Percentage Check-Weighing

This feature is commonly used in check-weigh applications. After a target weight is entered, upper and lower tolerances are entered as a percentage of the target. Over and under tolerance values are automatically calculated

according to the percentages entered. The desired target may be based on gross weight, net weight or quantity (if counting is enabled). Only the annunciators will light to indicator the setpoint status. Physical setpoints cannot be added at this time. The setpoint modules will be available in the near future and will be installed in a safe area hub.

Table 23: Setpoint Setup (Percentage Check-Weighing)

Setpoint Selection	Function	Description
P5100.1	ChecP	Check-weigh by percentage.
P5101.--	Targ1	Absolute target value.
P5102.--	PctLo	Low acceptance percentage.
P5103.--	PctHi	High acceptance percentage.
P5104.0	Based	Select from <i>Net</i> , <i>Gross</i> or <i>Quantity</i> .

See *Key-In Parameters* on page 43 for instructions on using the front panel keys for entering data.

SETPOINT ACTIVATION (PERCENTAGE CHECK-WEIGHING)



In order for the annunciators to activate, the displayed value must be at least five graduations above zero.

Check-Weigh Status	Annunciator Status	Annunciator Color (LED)
OVER	SP 1 Illuminated	Red
GOOD	SP 2 Illuminated	Green
UNDER	SP 3 Illuminated	Yellow





The Pre-Acts, Learn Mode, and Pause Feature options are not applicable to check-weigh operation.

CHANGING TARGETS FROM THE WEIGH MODE (PERCENTAGE CHECK-WEIGHING)

When Check-Weigh by Percentage is configured in the setpoint setup, the Targ 1 value automatically becomes an available mode for the  key. Keying in a value before pressing  changes Targ 1. Targ 1 is entered as an absolute value. Pressing  alone gives access to the subsets. PctLo and PctHi are the subsets for Targ 1. PctLo and PctHi are entered as percentage values.

To change targets from the Weigh Mode:

1. Press  to view the current net weight.
DISPLAY READS ►0.00
2. Press  to view the current fill target.
DISPLAY READS ►Targ1 ~ 250

3. Press **4** **0** **0** **TARE** or **4** **0** **0** **SAMPLE ENTER** to set a new fill target of 400 lbs.

DISPLAY READS ►Targ1 ~ 400

4. Press **TARE** or **SAMPLE ENTER** to select the Pre-Act 1 (subset) value of 28 lbs.

DISPLAY READS ►PA 1 ~ 28

5. Press **TARE** or **SAMPLE ENTER** to select the Pre-Act 2 (subset) value of 1.5 lbs.

DISPLAY READS ►PA 2 ~ 1.5

6. Press **.** **5** **TARE** or **.** **5** **SAMPLE ENTER** to select a new Pre-Act 2 value of .5 lbs.

DISPLAY READS ►PA 2 ~ .5

7. Press **SELECT** to display the current Gross Weight.

DISPLAY READS ►15.12

EXAMPLE (PERCENTAGE CHECK-WEIGHING)

With a system set up to check-weigh ice cream containers, the following settings might be used to guarantee container weights from 1.98 to 2.04 lbs.:

Parameter Setting	Acceptable Check-weigh Values	Comments
Target = 2.00		Desired container weight.
Percent Lo Value = 1	$2.00 * .01 = 0.02$	Low acceptable range = 1.98 to 2.00.
Percent Hi Value = 2	$2.00 * .02 = 0.04$	High acceptable range = 2.00 to 2.04.

Absolute Check-Weighing

This program is commonly used for check-weigh applications. After a target weight is entered, upper and lower tolerances are entered as absolute values. Over and Under tolerances are also entered as absolute values. The desired target may be based on gross weight, net weight, or quantity (if counting is enabled). Only the annunciators will light to indicate the setpoint status. Physical setpoints cannot be added at this time. The setpoint modules will be available in the near future and will be installed in a safe area hub.

Table 24: Setpoint Setup (Absolute Check-Weighing)

Setpoint Selection	Function	Description
P5100.6	ChecA	Check-weigh by absolute value.
P5101.--	Targ1	Absolute target value.
P5102.--	Lo	Low acceptance value.
P5103.--	Hi	High acceptance value.
P5104.0	Based	Select from <i>Net</i> , <i>Gross</i> or <i>Count (Quantity)</i> .

See *Key-In Parameters* on page 43 for instructions on using front panel keys for entering data.

SETPOINT ACTIVATION (ABSOLUTE CHECK-WEIGHING)

In order for the annunciators or setpoints to activate, the displayed value must be at least five graduations above zero. A setpoint option board may be installed to allow the Model 350 to directly control lights, buzzers, drop-gates, or reject devices.

Check-Weigh Status	Annunciator Status	Annunciator Color (LED)
OVER	SP 1 Illuminated	Red
GOOD	SP 2 Illuminated	Green
UNDER	SP 3 Illuminated	Yellow



The Pre-Acts, Learn Mode, and Pause Feature options are not applicable to check-weigh operation.

CHANGING TARGETS FROM THE WEIGH MODE (ABSOLUTE CHECK-WEIGHING)

When Check-Weigh by Absolute is configured in the setpoint setup, the Targ 1 value automatically becomes an available mode for the **SELECT** key. Keying in a value before pressing **TARE** changes Targ 1. Targ 1 is entered as an absolute value. Pressing **TARE** alone gives access to the subsets. Lo and Hi are the subsets for Targ 1. Lo and Hi are also entered as absolute values.

To change targets from the Weigh Mode:

1. Press **SELECT** to view the current net weight.
DISPLAY READS ►0.00
2. Press **SELECT** to view the current fill target.
DISPLAY READS ►Targ1 ~ 250
3. Press **4 0 0 TARE** or **4 0 0 SAMPLE ENTER** to set a new fill target of 400 lbs.
DISPLAY READS ►Targ1 ~ 400
4. Press **TARE** or **SAMPLE ENTER** to select the Pre-Act 1 (subset) value of 28 lbs.
DISPLAY READS ►PA 1 ~ 28
5. Press **TARE** or **SAMPLE ENTER** to select the Pre-Act 2 (subset) value of 1.5 lbs.
DISPLAY READS ►PA 2 ~ 1.5
6. Press **. 5 TARE** or **. 5 SAMPLE ENTER** to select a new Pre-Act 2 value of .5 lbs.
DISPLAY READS ►PA 2 ~ .5
7. Press **SELECT** to display the current Gross Weight.
DISPLAY READS ►15.12

EXAMPLE (ABSOLUTE CHECK-WEIGHING)

With a system set up to check-weigh 50 lb. cement bags, the following settings might be used check-weigh bag from 49.5 to 51.5 lbs.:

Parameter Setting	Acceptable Check-Weigh Values	Comments
Target = 50.00		Desired bag weight.
Low Value = 49.50	49.50 – 50.00 lbs.	Low acceptable range = 49.50 to 50.00 lbs.
High Value = 51.50	50.00 – 51.50 lbs.	High acceptable range = 50.00 to 51.50 lbs.

Remote Key Operation

The Model 350 and Model 355 have four selectable remote key operations to choose from: *Print*, *Tare*, *Zero* and *Setpoint*. Only one of these operations may be assigned to the remote key input. Table 25 describes the available remote key operations. See *Remote Key Connection* on page 12 for information on connecting a remote key input device.

Table 25: Remote Key Operations

Remote Key Selection	Function	Description
P800.00	None	Remote key disabled.
P800.01	Print	Initiates print function. Print restrictions (P200 – P212) will be adhered to.
P800.02	Tare	Initiates tare function. Tare restrictions (P161 - P169) will be adhered to.
P800.03	Zero	Initiates zero function. Zero restrictions (P118) will be adhered to.



Tare, Zero and Print functions will be delayed according to the stability setting (P114). If a setpoint operation is configured to use the remote key as an activation method, the P800 setting is over-ridden.

Remote Serial Operation

Table 26: Remote Serial Operation

Command	ASCII	HEX	Description
Print	%p	F0h	Initiates print function. Print restrictions (P200 – P212) will be adhered to.
Select	%s	F3h	Performs a parameter or mode select operation.
Tare	%t	F4h	Initiates tare function. Tare restrictions (P161 - P169) will be adhered to.
Units	%u	F5h	Toggles between displayed units of measure.
Zero	%z	FAh	Initiates zero function. Zero restrictions (P118) will be adhered to.
Enter	%e	E5h	Enters preceding data into selected register. Also toggles through selections in Setup Mode.

Command	ASCII	HEX	Description
Piece Wt. Entry	%9	B9h	Allows a piece weight to be entered serially. For example, 0.10%9 will enter a piece weight of 0.10.
Print	W<CR> or P<CR>	57h, 0Dh	Initiates print function. Print restrictions (P200-P212) will be adhered to. Requires both hex values, 57h followed by 0Dh.
Zero	Z<CR>	5Ah, 0Dh	Initiates zero function. Zero restrictions (118) will be adhered to. Requires both hex values, 5Ah followed by 0Dh.

<CR> is a carriage return, decimal value 013, hex value 0Dh.

DISPLAY CAPTURE UTILITY

The Display Capture Utility sends the current display information out of the comm port when the extended ASCII character represented by decimal 149 (hex: 95h) is received through the comm port. Entering a decimal 149 from a computer keyboard can be accomplished by turning on the Num Lock and holding down the ALT key while typing the desired decimal number on the keyboard keypad (for example, <Alt>149).



The Display Capture Utility must have NTEP disabled in order to function.

EXAMPLE #1

The scale is in the weigh mode with the gross weight displayed (for example, 15.00).

Input: The extended ASCII character represented by decimal 149 (hex: 95h) is received through the comm port.

Output: “15.00 lb Gross ” is sent out the comm port.

EXAMPLE #2

The scale is in setup at P110 Full Scale.

Input: The extended ASCII character represented by decimal 149 (hex: 95h) is received through the comm port.

Output: “P110 F.S. 100.00 ” is sent out the comm port.

Time and Date Setup (Model 350)

The time and date feature is stored as non-volatile (time/date setting will not be lost when the unit power is reset). The time/date parameter is available in the first two fixed transmits (See *Transmit Selection on page 50*) and can be included in a custom transmit (See *Custom Transmit Setup on page 55*).











Upon power up and with P502 set to Enabled, the display will toggle *Enter ~ Date~01.01.70*. If the date is acceptable, press the .

To enter the date from the *Enter~date~01.01.70* prompt

EXAMPLE: 01.09.04 (January 9, 2004)









1. Press  to toggle through the numbers to enter the month.





DISPLAY READS ► 1

2. Press  twice to move the decimal point over to separate the month from the day. It is not necessary to enter a 0 before a single digit month. If it is a double-digit entry, press  once to move the cursor and then  to scroll through the digits.
DISPLAY READS ► 1.
3. Press  to toggle through the numbers to enter the day.
DISPLAY READS ► 1.9
4. Press  twice to move the decimal point over to separate the day from the year. It is not necessary to enter a 0 before a single digit month. If it is a double-digit entry, press  once to move the cursor and then  to scroll through the digits.
DISPLAY READS ► 1.9.
5. Press  to toggle through the numbers to enter the year.
DISPLAY READS ► 1.9.0
6. Press  once to move the cursor and then press  to scroll through the digits.
DISPLAY READS ► 1.9.04
7. Press  twice to accept the entry.
DISPLAY READS ► 01.09.04

To enter the time from the *Enter~time~00.00.00* prompt

EXAMPLE: 16.32.41 (4:32:41 P.M.)

1. Press  to toggle through the numbers to enter the hour. Hours must be entered as military time.
DISPLAY READS ► 1
2. Press  once to move the cursor. Press  to select the next digit.
DISPLAY READS ► 16
3. Press  twice to move the decimal point over to separate the hour from the minutes. It is not necessary to enter a 0 before a single digit hour.
DISPLAY READS ► 16.
4. Press  to toggle through the numbers to enter the minutes.
DISPLAY READS ► 16.3
5. Press  once to move the cursor. Press  to select the next digit.
DISPLAY READS ► 16.32
6. Press  twice to move the decimal point over to separate the minutes from the seconds.
DISPLAY READS ► 16.32.

7. Press  to toggle through the numbers to enter the seconds. The seconds do not have to be entered. Press  to bypass entering the seconds.
DISPLAY READS ► 16.32.4
8. Press  once to move the cursor. Press  to select the next digit.
DISPLAY READS ► 16.32.41
9. Press  twice to accept the time entry. The date and time are now saved until power to the indicator is lost. The display will be returned to the weigh mode.
DISPLAY READS ► 0.00







Time and Date Setup (Model 355)

The time and date feature is stored as non-volatile (time/date setting will not be lost when the unit power is reset). The time/date parameter is available in the first two fixed transmits (See *Transmit Selection on page 50*) and can be included in a custom transmit (See *Custom Transmit Setup on pag 55*).

Upon power up and with P502 set to Enabled, the display will toggle *Enter ~ Date~01.01.70*. If the date is acceptable, press .









To enter the date from the *Enter~date~01.01.70* prompt

EXAMPLE: 01.09.04 (January 9, 2004)

1. Key in the date in the following format: 
DISPLAY READS ► 01.09.04
2. Press  to except the date and move to the time entry. Press  again to bypass the time entry.

To enter the time from the *Enter~time~00.00.00* prompt

EXAMPLE: 16.32.41 (4:32:41 P.M.)

1. Key in the date in the following format: 
DISPLAY READS ► 16.32.41
2. Press  to except the time and move to the weigh mode.

RS-485 Multi-Drop Network Setup and Operation

Table 27: RS-485 Network Parameters

PARAMETER SETTING	DISPLAYED NAME	DESCRIPTION	TYPE/CHOICES (*=DEFAULT)
P250.00	<i>rS485</i>	Enable or disable RS-485 network option.	Disbl*, Enabl
P251.00	<i>Addr</i>	Specifies the address of the controller for RS-485 Multi-Drop communications.	Numeric Entry: Disabled (0*) and 4 – 254

The RS-485 multi-drop network option supports both half duplex (2-wire) and full duplex (4-wire) modes of operation. The mode of operation is determined by setting jumpers 1–4 on the RS-485 option board.

Table 28: RS-485 Mode of Operation

JUMPER	HALF DUPLEX	FULL DUPLEX	DESCRIPTION
1	Installed	Open	Selects half or full duplex
2	Installed	Open	
3	Installed on the endpoints of the network	Installed on the endpoints of the network	Termination resistor (R8 – 121Ω)
4	Installed	Open	Receiver disabled when transmitting (if installed)

SETUP

The Model 350/355 controller supports address recognition, which allows a single master device to communicate with up to 250 distinct slave controllers. P250 must be enabled in order to gain access to P251. Enabling P250 by itself only causes the RTS line to become a driver enable for the RS-485 network option. Changing the P251 address to a value of 4 – 254 enables the network address recognition receive feature (i.e. networking).

OPERATION

When P251 is enabled by choosing a valid address, the Model 350/355 will ignore all data it receives until an <STX> character is followed immediately by a character that matches the address defined by setup parameter P251. If these two conditions are met then the Model 350/355 will process all subsequent data until the end of block character, <ETX>, is received, signaling the end of the transmission. The receive routine of the Model 350/355 then resets to look for the <STX> character again.

The *data packet* format recognized by the Model 350/355 is defined as follows:

<STX><ADDRESS><DATA><DATA><DATA><DATA>...<ETX>

Refer to Table 12: ASCII / HEXADECIMAL CONVERSION CHART on page 57 for <STX > and <ETX> ASCII codes. The address is a single byte decimal value (4 – 254). The <DATA> can be any information recognized by the Model 350/355, including direct commands – such as a %p (Print). This would direct the addressed unit to send its print transmission defined at P213 over the network.



If the received address character does not match P251 then all of the subsequent data is ignored until the next start of *packet* character, <STX>, is received.



An address of 0 at P251 will cause the Model 350/355 to process all received data.

NETWORK PROTOCOL

The protocol settings for the RS-485 network option board are the same as the protocol settings for RS-232. These settings are found starting at parameter P200.





All devices connected to the network must have matching protocol settings.

CHAPTER 5: CALIBRATION

Setup Mode Calibration

You can enter the Calibration Mode after accessing the Setup Mode to view and/or change parameter settings (see *Setup Mode* on page 40).







To access the Calibration Mode when viewing any setup parameter:

1. From the Setup Mode, press .
DISPLAY READS ► *Enter ~ =Cal!*
2. Press  or .
DISPLAY READS ► *First ~ Zero? ~ -0.26*











Fast Calibration

Fast Calibration allows calibration of the Model 350/355 scale system without accessing the Setup Mode.

To access Fast Calibration from the Weigh Mode (350):

1. From the Weigh Mode, press  + .
DISPLAY READS ► *Setup~Enter ~ Code!*
2. Press  →  →  → .
DISPLAY READS ► *Fast ~ Cal!~First ~ Zero? ~ -0.26*

To access Fast Calibration from the Weigh Mode (355):

1. From the Weigh Mode key in  .
DISPLAY READS ► *Setup~Enter ~ Code!*
2. Key in  .
DISPLAY READS ► *Fast ~ Cal!~First ~ Zero? ~ -0.26*

Fast Calibration can also be accessed if the following data stream is received via the comm port:

```
100%s54321%e
```

Performing Calibration

Calibration always begins by establishing a zero (no-load) reference. A complete calibration also requires establishing a span (test load) reference. This section details various methods for obtaining zero and span references.



Press or during calibration to back up one step in the procedure.

Establishing Zero

The Model 350/355 provides five methods for obtaining a zero (no load) calibration reference, First Zero, Last Zero, False Zero, Only Zero, and Cal Reset.

To select a calibration method (350):

1. Press + to display the calibration prompt.
2. Press → → → to access the Calibration Mode.
3. Press to scroll through the five selections.
4. Press to establish zero.

To select a calibration method (355):

1. Press to display the calibration prompt.
2. Press to access the Calibration Mode.
3. Press to scroll through the five selections.
4. Press to establish zero.

FIRST ZERO

The most common zeroing procedure, First Zero is used to establish a new zero (no load) calibration reference before proceeding to span the Model 350/355. Use this method for first-time calibration and complete recalibration.

First Zero Calibration Method Example (350):

1. From the Weigh Mode, press + .
- DISPLAY READS ► Setup**
2. Press → → → .
- DISPLAY READS ► Fast ~ Cal~First ~ Zero? ~ -0.26**
3. Remove any load on the scale.
- DISPLAY READS ► First ~ Zero? ~ -0.42**
4. Press to establish zero.
- DISPLAY READS ► 0.00**
5. Pause for motion delay.

- DISPLAY READS ► *Enter ~ Load ~ 0.00***
- Place a 100lb test weight on scale.
DISPLAY READS ► *Enter ~ Load ~ 99.66*
 - Enter .
 - DISPLAY READS ► *100***
 - Press to establish span.
DISPLAY READS ► *100.00*
 - Pause for motion delay.
DISPLAY READS ► *Cal ~ Good? ~ 100.00*
 - Press to accept calibration.
DISPLAY READS ► *Enter ~ =Stor*
 - Press to save calibration.
DISPLAY READS ► *Enter ~ =End*
 - Press to exit calibration.
DISPLAY READS ► *100.00*
 - Remove the calibration weight.
DISPLAY READS ► *0.00*

First Zero Calibration Method Example (355):

- From the Weigh Mode key in .
- DISPLAY READS ► *Setup***
- Key in .
- DISPLAY READS ► *Fast ~ Cal~First ~ Zero? ~ -0.26***
- Remove any load on the scale.
DISPLAY READS ► *First ~ Zero? ~ -0.42*
- Press to establish zero.
DISPLAY READS ► *0.00*
- Pause for motion delay.
DISPLAY READS ► *Enter ~ Load ~ 0.00*
- Place a 100lb test weight on scale.
DISPLAY READS ► *Enter ~ Load ~ 99.66*
- Enter .
- DISPLAY READS ► *100***
- Press to establish span.

DISPLAY READS ► 100.00

9. Pause for motion delay.

DISPLAY READS ► Cal ~ Good? ~ 100.00

10. Press  to accept calibration.

DISPLAY READS ► Enter ~ =Stor

11. Press  to save calibration.

DISPLAY READS ► Enter ~ =End

12. Press  to exit calibration.

DISPLAY READS ► 100.00

13. Remove the calibration weight.

DISPLAY READS ► 0.00

LAST ZERO

The Last Zero procedure allows recalibration of the weighing device using an existing test load. This is especially beneficial when checking high capacity applications such as tank weighing to minimize the task of placing and removing test weights.



Establish gross zero *before* entering setup or calibration!

Last Zero Calibration With Weight Already Applied Example (350):

1. Remove any load on the scale.

DISPLAY READS ► 10.

2. Press  to zero the scale.

DISPLAY READS ► 00.

3. Apply a 10000 lb test weight to verify calibration.

DISPLAY READS ► 9970.

4. Press  + .

DISPLAY READS ► Setup

5. Press  →  →  → .

DISPLAY READS ► Fast ~ Cal~First ~ Zero? ~ 9930.

6. Press .

DISPLAY READS ► Last ~ Zero? ~9930.





7. Press  to use last zero.

DISPLAY READS ► Enter ~ Load? ~ 9970.

8. Enter .
DISPLAY READS ► 10000
9. Press to establish span.
DISPLAY READS ► 10000.
10. Pause for motion delay.
DISPLAY READS ► Cal ~ Good? ~ 10000.
11. Press to accept calibration.
DISPLAY READS ► Enter ~ =Stor
12. Press to save calibration.
DISPLAY READS ► Enter ~ =End
13. Press to exit calibration.
DISPLAY READS ► 10000.
14. Remove the calibration weight.
DISPLAY READS ► 0.

Last Zero Calibration With Weight Already Applied Example (355):















1. Remove any load on the scale.
DISPLAY READS ► 10.
2. Press to zero the scale.
DISPLAY READS ► 00.
3. Apply a 10000 lb test weight to verify calibration.
DISPLAY READS ► 9970.
4. Press .
- DISPLAY READS ► Setup**
5. Press .
- DISPLAY READS ► Fast ~ Cal~First ~ Zero? ~ 9930.**
6. Press .
- DISPLAY READS ► Last ~ Zero? ~9930.**
7. Press to use last zero.
DISPLAY READS ► Enter ~ Load? ~ 9970.
8. Enter .
- DISPLAY READS ► 10000**



9. Press  to establish span.
DISPLAY READS ► 10000.
10. Pause for motion delay.
DISPLAY READS ► Cal ~ Good? ~ 10000.
11. Press  to accept calibration.
DISPLAY READS ► Enter ~ =Stor
12. Press  to save calibration.
DISPLAY READS ► Enter ~ =End
13. Press  to exit calibration.
DISPLAY READS ► 10000.
14. Remove the calibration weight.
DISPLAY READS ► 00.

FALSE ZERO



















False Zero calibrates the Model 350/355 without removing the current gross weight. This is particularly useful in tank weighing applications where it may be both time consuming and costly to completely empty the tank. This operation is achieved by establishing a false (temporary zero) zero reference. Test weights may then be added to verify calibration. The zero reference determined during the last calibration is not affected.



False Zero Calibration Without Removing Existing Load Example (350):

1. Press  + .
- DISPLAY READS ► Setup**
2. Press  →  →  → .
- DISPLAY READS ► Fast ~ Cal~First ~ Zero? ~ 5075.**
3. Press  .
- DISPLAY READS ► False ~ Zero? ~5075.**
4. Press  to establish false (temporary) zero.
DISPLAY READS ► Units ~ =lb
5. Pause to display calibration units.
DISPLAY READS ► Enter ~ Load? ~ 00.
6. Place a 2500lb test weight on scale.
DISPLAY READS ► Enter ~ Load? ~ 2510.
7. Enter    .
- DISPLAY READS ► 2500**
8. Press  to establish span.

- DISPLAY READS ► 2500.**
- Pause for motion delay.
DISPLAY READS ► Cal ~ Good? ~ 2500.
 - Press  to accept calibration.
DISPLAY READS ► Enter ~ =Stor
 - Press  to save calibration.
DISPLAY READS ► Enter ~ =End
 - Press  to exit calibration.
DISPLAY READS ► 5055.
 - Remove the calibration weight.
DISPLAY READS ► 00.

False Zero Calibration Without Removing Existing Load Example (355):













- Press    .
- DISPLAY READS ► Setup**
- Press      .
- DISPLAY READS ► Fast ~ Cal~First ~ Zero? ~ 5075.**
- Press  .
- DISPLAY READS ► False ~ Zero? ~5075.**
- Press  to establish false (temporary) zero.
DISPLAY READS ► Units ~ =lb
- Pause to display calibration units.
DISPLAY READS ► Enter ~ Load? ~ 00.
- Place a 2500lb test weight on scale.
DISPLAY READS ► Enter ~ Load? ~ 2510.
- Enter    .
- DISPLAY READS ► 2500**
- Press  to establish span.
DISPLAY READS ► 2500.
- Pause for motion delay.
DISPLAY READS ► Cal ~ Good? ~ 2500.
- Press  to accept calibration.
DISPLAY READS ► Enter ~ =Stor

11. Press  to save calibration.
DISPLAY READS ► *Enter ~ =End*
12. Press  to exit calibration.
DISPLAY READS ► *5055*
13. Remove the calibration weight.
DISPLAY READS ► *00*











ONLY ZERO

Only Zero is used to establish a new calibration zero without affecting the span. This is useful for correcting changes to the scale's dead load, for example adding safety rails to a truck scale platform.

Only Zero Calibration Example (350):

1. From the Weigh Mode, press  + .
- DISPLAY READS ► *Setup***
2. Press  →  →  → .
- DISPLAY READS ► *Fast ~ Cal~First ~ Zero? ~2640***
3. Press   .
- DISPLAY READS ► *Only ~ Zero? ~ 2640***
4. Remove any load on the scale.
DISPLAY READS ► *Only ~ Zero? ~ 2620*
5. Press  to establish zero.
DISPLAY READS ► *00*
6. Pause for motion delay.
DISPLAY READS ► *Cal ~ Good? ~ 00*
7. Press  to accept calibration.
DISPLAY READS ► *Enter ~ =Stor*
8. Press  to save calibration.
DISPLAY READS ► *Enter ~ =End*
9. Press  to exit calibration.
DISPLAY READS ► *00*

Only Zero Calibration Example (355):

1. From the Weigh Mode, press    .
- DISPLAY READS ► *Setup***
2. Press      .

DISPLAY READS ► *Fast ~ Cal~First ~ Zero? ~2640.*

3. Press   .

DISPLAY READS ► *Only ~ Zero? ~ 2640.*

4. Remove any load on the scale.

DISPLAY READS ► *Only ~ Zero? ~ 2620.*

5. Press  to establish zero.

DISPLAY READS ► *00.*

6. Pause for motion delay.

DISPLAY READS ► *Cal ~ Good? ~ 00.*

7. Press  to accept calibration.

DISPLAY READS ► *Enter ~ =Stor*

8. Press  to save calibration.

DISPLAY READS ► *Enter ~ =End*

9. Press  to exit calibration.

DISPLAY READS ► *00.*

RESET CALIBRATION

Cal Reset may be necessary when an over-load or under-load condition exists, preventing the completion of the calibration process. Calibration Reset adjusts the zero and gain factors of the A/D amplifier to factory default values for maximum sensitivity.

After performing a calibration reset, a complete recalibration is required. The effects of a calibration reset do not take effect until the Model 350/355 recalibrated and calibration information has been saved.



If **Code 02** (under-load) or **Code 03** (over-load) is displayed during calibration, press  to perform a calibration reset.

Reset Calibration Gain Factors Example (350):

1. Press  + .

DISPLAY READS ► *Setup*

2. Press  →  →  → .

DISPLAY READS ► *Fast ~ Cal~First ~ Zero? ~ xx.xx*

3. Remove any load on the scale.

DISPLAY READS ► *First ~ Zero? ~ xx.xx*











4. Press  to establish zero.

DISPLAY READS ► *Enter ~ Load? ~ 0.00*

5. Place a 100lb test weight on scale.
DISPLAY READS ► Code03
6. Press .
DISPLAY READS ► First ~ Zero? ~ -0.26
7. Remove any load on the scale.
DISPLAY READS ► First ~ Zero? ~ -0.42
8. Press to establish zero.
DISPLAY READS ► 0.00
9. Pause for motion delay.
DISPLAY READS ► Enter ~ Load ~ 0.00
10. Place a 100lb test weight on scale.
DISPLAY READS ► Enter ~ Load ~ xx.xx
11. Enter 100 with the and keys.
DISPLAY READS ► 100
12. Press to establish span.
DISPLAY READS ► 100.00
13. Pause for motion delay.
DISPLAY READS ► Cal ~ Good? ~ 100.00
14. Press to accept calibration.
DISPLAY READS ► Enter ~ =Stor
15. Press to save calibration.
DISPLAY READS ► Enter ~ =End
16. Press to exit calibration.
DISPLAY READS ► 100.00
17. Remove the calibration weight.
DISPLAY READS ► 0.00



Reset Calibration Gain Factors Example (355):

1. Press .
- DISPLAY READS ► Setup**
2. Press .
- DISPLAY READS ► Fast ~ Cal~First ~ Zero? ~ xx.xx**
3. Remove any load on the scale.
DISPLAY READS ► First ~ Zero? ~ xx.xx

4. Press  to establish zero.
DISPLAY READS ► *Enter ~ Load? ~ 0.00*
5. Place a 100lb test weight on scale.
DISPLAY READS ► *Code03*
6. Press .
- DISPLAY READS ► *First ~ Zero? ~ -0.26***
7. Remove any load on the scale.
DISPLAY READS ► *First ~ Zero? ~ -0.42*
8. Press  to establish zero.
DISPLAY READS ► *0.00*
9. Pause for motion delay.
DISPLAY READS ► *Enter ~ Load ~ 0.00*
10. Place a 100lb test weight on scale.
DISPLAY READS ► *Enter ~ Load ~ xx.xx*
11. Enter .
- DISPLAY READS ► *100***
12. Press  to establish span.
DISPLAY READS ► *100.00*
13. Pause for motion delay.
DISPLAY READS ► *Cal ~ Good? ~ 100.00*
14. Press  to accept calibration.
Enter ~ =Stor
15. Press  to save calibration.
DISPLAY READS ► *Enter ~ =End*
16. Press  to exit calibration.
DISPLAY READS ► *100.00*
17. Remove the calibration weight.
DISPLAY READS ► *0.00*



Establishing A Span



Once a zero reference has been established, the Model 350/355 displays ***Enter ~ Load*** and awaits the entry of a span (test load) value. This value may be entered before or after the test load has been applied.

If the calibration weight value was entered before applying the test weight, **Add ~ Load** is displayed indicating that the test weight should now be applied. Apply the test weight, press  or  and proceed to *Exiting Calibration* on page 59.

If it is necessary to repeat the calibration process, press  at the **Cal ~ Good?** prompt and repeat the calibration process.

Establishing span with a 100lb test weight:







1. Place a 100lb test weight on scale.
DISPLAY READS ► Enter ~ Load ~ xx.xx
2. Enter 100.
DISPLAY READS ► 100
3. Press  or  to establish span.
DISPLAY READS ► 100.00
4. Pause for motion delay.
DISPLAY READS ► Cal ~ Good? ~ 100.00

When making a significant change to the previous calibration, or when the calibration weight is less than 5% of full scale capacity, **ReCal ~ ???** will be displayed instead of **Cal ~ Good?** In this event it is recommended that the calibration be performed a second time. Press  or  to recalibrate, or press  to skip recalibration.



Exiting Calibration

Once zero and span have been established, the newly acquired calibration information must be saved to non-volatile memory before it will be realized in the Weigh Mode.

To exit and save calibration information:

1. Press  or  to accept calibration.
DISPLAY READS ► Enter ~ =Stor
2. Press  or  to save calibration.
DISPLAY READS ► Enter ~ =End
3. Press  or  to exit calibration.
DISPLAY READS ► 100.00

To exit without saving calibration information:

1. Press  or  to accept calibration.
DISPLAY READS ► Enter ~ =Stor
2. Press .
DISPLAY READS ► Enter ~ =Undo

3. Press  or .

DISPLAY READS ► *Enter ~ =End*

4. Press  or  to exit calibration.

DISPLAY READS ► *99.66*



When saving calibration, parameters changed in the Setup Mode are also saved with their new selections.

CHAPTER 6: LEGAL FOR TRADE

The Model 350/355 default parameter setup does not ensure compliance with legal-for-trade installations as mandated by local weights and measures authorities. This chapter contains information on NTEP and OIML regulations, sealing and audit trails, and other requirements.

Since legal-for-trade requirements may vary, you must ensure that the Model 350/355 installed in accordance with all local regulations.

NTEP Requirements

The National Type Evaluation Program (NTEP) is a widely accepted weights and measures standard in the United States, with most states abiding by some or all of the NTEP requirements. A complete list of these regulations is available in the “Handbook 44” publication distributed by the National Institute of Standards and Technology (NIST). For more information, call (301) 975-3058, or visit <http://www.nist.gov>.



The Model 350/355 NTEP Certificate of Conformance (C.O.C.) is 98-092A2.

In order to configure the Model 350 to comply with NTEP requirements, parameter P440-rstrc (*restrict*) must be enabled. This ensures the following:

- Serial data will not be received while in the Setup Mode.
- Received alpha characters will not be displayed.
- Numeric tare entries cannot be received through the serial port.
- Pressing  with a gross weight of zero (0) will not automatically switch to the net mode.
- Negative tare values are not accepted.
- Tare rounding is enforced.
- When the tare value is zero, the net mode is not selectable.

Where applicable, enabling the *restrict* parameter will over-ride the current setting of other parameters.



If the counting feature is enabled, NTEP requires a label on the front of the indicator stating “*The counting feature is not legal for trade*”. See *Other Requirements* on page 102 for other application specific considerations.

NTEP Panel Mount Requirements

In addition to all other NTEP requirements, the serial number of a panel mounted unit must be visible from the outside front of the controller. The serial number on the Model 350 rear label must be *engraved* in the space provided on the panel mount tag (see *Figure 36*). These serial numbers **MUST** match. The tag is designed to be applied to the *top right edge* of the enclosure or to the *lower right of the front* of the unit. Drill pins (GSE part number 38-04-2960) are supplied with the panel mount kit to mount the tag. The drill pins require a 1/16” hole.

To install the panel mount tag:

1. Remove the electronics.
2. Carefully score the case so the drill will not slip.
3. Drill the mounting holes with a 1/16” drill.
4. Gently tap the drill pins to secure the label to the case.
5. Clean out the case.
6. Re-install the electronics.



Damage to the case or electronics is not covered by warranty.



The NTEP panel mount requirements are applicable only to the Model 350 die cast model and panel mount kit.



Figure 36: Panel Mount Unit - Serial Number Tag (Die Cast Model)

OMIL Requirements

The International Organization of Legal Metrology is an inter-governmental body which harmonizes the national metrology regulations of its world wide members. A list of regulation publications may be obtained from the Bureau International de Métrologie Légale (BIML) in Paris, France.

In order to configure the Model 350 to comply with OIML requirements, parameter P410-Euro must be enabled. Doing so will ensure the following:

- An over-load condition will result when the gross weight exceeds nine graduations over the full scale capacity.
- Full scale capacity is always referenced from the last zero calibration reference, not the last zero acquired by pressing .

Most NTEP requirements will also apply. See the *Other Requirements* section below for additional considerations.

Other Requirements

Several parameters must be considered on an individual basis as their configuration may vary with different applications. These parameters include, but are not limited to:

Parameter	Description	COMMENT
P110	Full Scale Capacity	Verify proper scale capacity.
P111	Division Size	Verify that the maximum allowable number of scale divisions are not exceeded.
P112	Zero Track	Verify required selection.
P114	Stability	Verify required selection.
P118	Zero Range	Verify required selection.
P212	Print Stability	Verify required selection.

Sealing And Audit Trails

Most legal-for-trade installations will require the Model 350/355 to be sealed. A sealed indicator cannot be accessed for setup or calibration changes without breaking a physical seal or incrementing an event counter, thus providing evidence of tampering.

The Model 350/355 has two types of sealing provisions, a physical seal and a three event audit trail counter. Check with your local weights and measures authority to determine your requirements.

PHYSICAL SEAL

The most common sealing method is a lead-wire seal. The Model 350 and Model 355 provide an easy means of applying this type of seal as shown in *Figure 38*.

Before applying a wire seal, move the program jumper to the 'NO' position as shown in *Figure 37*. This will prevent access to the Setup and Calibration Modes.

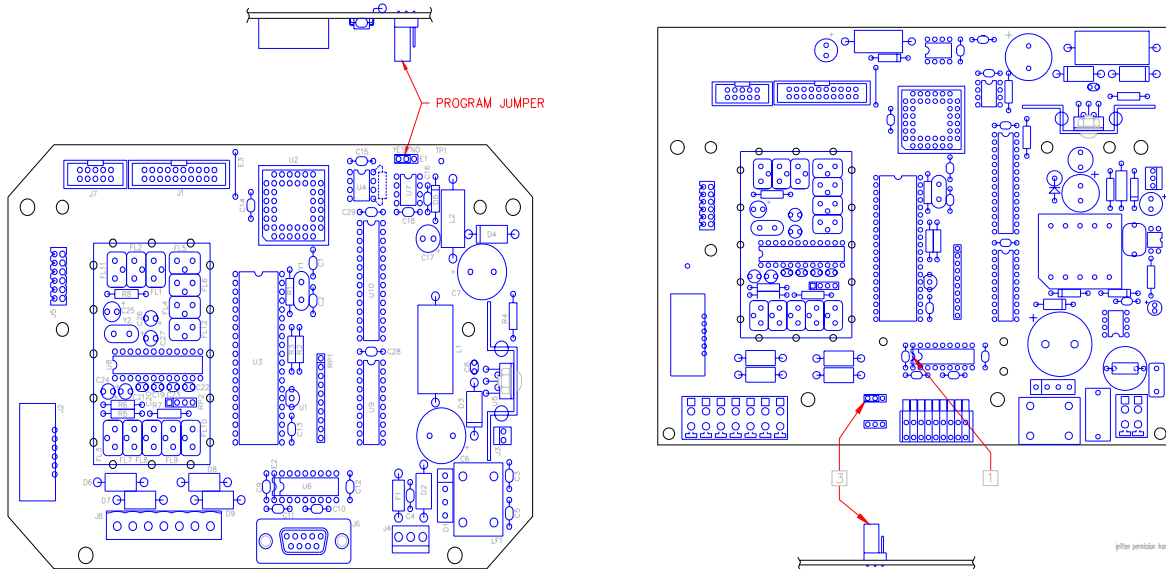

Figure 37: Program Jumper (External and Internal Power Supply Boards)

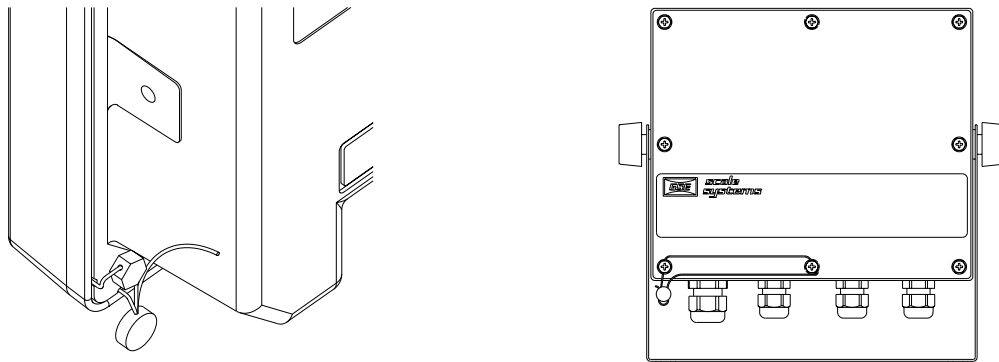

Figure 38: Physical Seals (Zinc Die-Cast / Stainless Steel)

AUDIT TRAILS

Three separate incrementing, non-resetable audit trail parameters are used by the Model 350/355 to indicate changes to various parameters, P60201 – OIML, P60203 – Calibration , and P60204 – Setup. An audit trail counter will increment only once upon exiting the Setup Mode and saving changes regardless of how many settings were changed.

OIML AUDIT TRAIL

Changes to any of the following parameters will increment the OIML (Euro) audit trail at P60201:

- P110 – P118 (scale setup)
- P150 (default units)
- P151 (units enable)
- P410 (Euro enable)
- P440 (rStrc enable)
- Existing Calibration

CALIBRATION AUDIT TRAIL

Any changes to the existing calibration will increment the Calibration (CAL) audit trail at P60203.









SETUP AUDIT TRAIL

Changes to any of the Setup Mode parameters will increment the setup audit trail at P60204.

VIEWING AUDIT TRAIL PARAMETERS

Audit trail parameters may be viewed at any time.

To view audit trail parameters: (Model 350)

1. Press  + .
- DISPLAY READS ► Setup~Enter ~ Code!**
2. Press .
- DISPLAY READS ► -No- ~ Chgs!~P110 ~ FS ~ xx.xx**
3. Enter [60203] with the  and  keys.
- DISPLAY READS ► 60203**
4. Press  to view the selected audit trail.
- DISPLAY READS ► Audit ~ Trail~CAL. ~ 00001**
5. Press  again to view the Setup Audit Trail parameter.
- DISPLAY READS ► Audit ~ Trail~Setup. ~ 00003**
6. Press  to return to the Weigh Mode.
- DISPLAY READS ► 0.00**







To view audit trail parameters: (Model 355)

1. Press    

DISPLAY READS ► *Setup~Enter ~ Code!*

2. Press .

DISPLAY READS ► *-No- ~ Chgs!~P110 ~ FS ~ xx.xx*

3. Press      .

DISPLAY READS ► *Audit ~ Trail~CAL. ~ 00001*

4. Press  again to view the Setup Audit Trail parameter.

DISPLAY READS ► *Audit ~ Trail~Setup. ~ 00003*

5. Press  to return to the Weigh Mode.

DISPLAY READS ► *0.00*

CHAPTER 7: TROUBLESHOOTING

This chapter contains error messages and information parameters, as well as information on setup parameter selections and A/D Calibration.

Error Messages

The Model 350/355 utilizes the following types of error messages: *Operational Errors*, *Setup Mode Errors*, *Hardware Errors*, *Calibration Errors*, *Communication Errors*, and *Miscellaneous Errors*.

OPERATIONAL ERRORS

<i>Code02</i>	Under Load. Input signal is less than negative full scale. Check load cell wiring. Verify correct capacity selection at P110.
<i>Code03</i>	Over Load. Input signal is greater than positive full scale. Use same checks as “under load” above.
<i>Funct ~ Disbl</i>	Attempted to perform a function disabled in the Setup Mode.
<i>Code 04</i>	The digits on the display have exceed the six digit display capacity.
<i>Code 05</i>	Zero attempted beyond that allowed by P118.
<i>Code 08</i>	Input signal greatly exceeds the valid range. Check the load cell connection.
<i>Tare ~ Error</i>	Negative tare attempted when disabled (P440 enabled).
<i>Tare ~ GT FS</i>	Tare value greater than full scale capacity.
<i>Delay</i>	Indicates that a motion delay is in effect (zero, tare, etc.).
<i>Delay ~ Abort</i>	Acknowledges that a motion delayed function was aborted.
<i>Print ~ Abort</i>	Acknowledges that a motion delayed print request was aborted.
<i>Add ~ Load!</i>	If displayed after performing a count sample, this message indicates that a larger sample size is required.
<i>Out of ~ Range</i>	Attempted to enter a value beyond the allowable range.
<i>SPTxx ~ Error</i>	A conflict occurred with a setpoint value entry (example: target entry is less than preact). The digits ‘xx’ represent the last two digits of the setpoint parameter in error (example: <i>SPT 5 ~ Error</i> indicates a conflict at P510 ₅ , preact 1).
<i>Need APS</i>	A setpoint <i>start</i> is initiated and the setpoint is based on <i>quantity</i> and no piece weight has been established (start will not occur).

SETUP MODE ERRORS

<i>Bad ~ Code!</i>	An incorrect access code was entered.
<i>Unit ~ Seald</i>	Access to the Setup or Calibration Mode was denied. Check the internal “YES/NO” program jumper.
<i>Unit3-Ntep Code 49.</i>	Parameter 440 (NTEP) is enabled and parameter 152 (third unit) is set to an additional unit. The third unit is not NTEP approved.
<i>Entry ~ Error</i>	An invalid entry was made.
<i>Need ~ Entry</i>	A numeric value was required before pressing  .
<i>Out of ~Range</i>	The entered value exceeded the allowable range.
<i>Can't ~ Set!</i>	Attempt to change a parameter that does not allow an entry.
<i>ResGT ~ 260E3 Code 35.</i>	The number of divisions exceeds 260000 (see P110, P111).
<i>ResGT ~ 25E3</i>	The number of divisions exceeds 25000 (see P110, P111).
<i>ResLT ~ 100!</i>	The number of divisions is less than 100 (see P110, P111).
<i>ResLT ~ 1 !!</i>	Number of divisions is less than one (see P110, P111).
<i>SPTxx ~ Error</i>	A conflict occurred with a setpoint value entry (example: target entry is less than preact). The digits ‘xx’ represent the last two digits of the setpoint parameter in error (example: <i>SPT 5 ~ Error</i> indicates a conflict P510 <u>5</u> , preact 1).
<i>Prtcl ~ Error</i>	Existing protocol is invalid. The following are not allowed: - P201 = 7 data bits, P202 = no parity, P203 = 1 stop bit - P201 = 8 data bits, P202 = even parity, P203 = 2 stop bits - P201 = 8 data bits, P202 = odd parity, P 203 = 2 stop bits

HARDWARE ERRORS

<i>Code00</i>	An EPROM problem detected during power-up (U2).
<i>A-D ~ Bad! Or Code17</i>	Problem with A/D chip detected. Disconnect any options installed and re-power the unit. Options are connected to the same serial lines as the A/D so they may prevent it from working properly.
<i>Deflt ~ A-D</i>	Bad A/D calibration values. Recalibrate A/D (see <i>A/D Calibration Procedure</i> on page 111).
<i>Re- ~ Boot!</i>	EEPROM data could not be read. Attempting power-up reset.
<i>Chec ~ E2</i>	EEPROM data error (U4).
<i>Deflt ~ Setup</i>	An error occurred when reading setup data from the EEPROM during power-up. All parameters are set to factory default.
<i>Ch.XXXX</i>	A checksum error occurred during power-up. All annunciators are lit. The EPROM integrity test failed or is improperly seated.
<i>E2 ~ Full!</i>	The EEPROM setup exceeds the memory capacity.
<i>NoSpc ~ Free!</i>	The current setup exceeds the setup RAM capacity.

CALIBRATION ERRORS

<i>F.S. ~ TooHi</i>	The entered calibration weight will result in an over-capacity condition at full scale. Verify that the full scale (P110) and calibration weight value are correct.
<i>F.S. ~ TooLo</i>	The entered calibration weight will result in a full scale input signal less than the minimum allowed. Verify that the full scale (P110) and entered weight value are correct.
<i>Add ~ Load!</i>	The calibration weight is less than 0.1% of capacity. More weight is required.
<i>ReCal ~ ???</i>	Repeat the cal. procedure for accuracy. This prompt appears when the calibration weight is less than 5% of capacity, or when the A/D coarse gain is adjusted.
<i>Entry ~ Error</i>	An invalid entry was made.

COMMUNICATION ERRORS

<i>Par-Er</i>	The selected parity (P202) does not match that of the connected device.
<i>Buf-Er</i>	The receive buffers capacity was exceeded. This indicates a handshaking problem. Check P204 and verify proper communication port connections.
<i>Bit-Er</i>	The stop bit of a received character did not occur when expected. Verify that protocol (P200 – P204) matches that of the connected device.
<i>TrHold</i>	Data transmission is inhibited due to a deasserted handshake. Press <input type="button" value="ZERO CLR"/> or <input type="button" value="CLR NO"/> to abort transmission. Check P204.

MISCELLANEOUS ERRORS

<i>T.X.YYYY</i>	If catastrophic errors occur in the software, a trap error may occur and freeze the display with address information. (X = bank number and YYYY = the address of the trap error. Press any key five seconds after viewing message to reboot the unit).
------------------------	--

Viewing Setup

While troubleshooting it may be helpful to view the setup parameter selections. This can be done using the procedure below (even with the internal program jumper in the “NO” position). Note that accessing the Setup Mode in this manner will not permit parameter changes.

To view the setup parameter selections (350):

- From the Weigh Mode, press + .
DISPLAY READS ► *Setup~Enter ~ Code!*
- Press .
DISPLAY READS ► *-No- ~ Chgs!~P110.-- ~ F.S.= ~ 100.0*
- Navigate the Setup Mode as described in *Setup Mode* on page 40.

To view the setup parameter selections (355):

1. From the Weigh Mode, press **1** **0** **0** **SELECT**.
DISPLAY READS ► Setup~Enter ~ Code!
2. Press **SAMPLE ENTER**.
DISPLAY READS ► -No- ~ Chgs!~P110.-- ~ F.S.= ~ 100.0
3. Navigate the Setup Mode as described in *Setup Mode* on page 40.

To exit the Setup Mode:

1. Press **ZERO**.
2. Press **SAMPLE ENTER**.

Information Mode Parameters

A series of informational parameters are available beginning at P60000. These parameters may be accessed from the Setup Mode, or from the Weigh Mode as described below. Table 29 gives an explanation of each information parameter.

To access the informational parameters (350):









1. Press **ZERO CLR** + **SELECT ON**.
DISPLAY READS ► Setup~Enter ~ Code!
2. Press **ZERO CLR** → **PRINT** → **UNITS** → **TARE**.
DISPLAY READS ► P60000 ~ E2Ins ~ 512
3. Navigate the Setup Mode as described in *Setup Mode* on page 40.





To access the informational parameters (355):

4. Press **1** **0** **0** **SELECT**.
DISPLAY READS ► Setup~Enter ~ Code!
5. Press **6** **0** **0** **0** **0** **SAMPLE ENTER**.
DISPLAY READS ► P60000 ~ E2Ins ~ 512
6. Navigate the Setup Mode as described in *Setup Mode* on page 40.

As each information parameter is accessed, the parameter number is briefly displayed, followed by the parameter name, and finally the parameter value. To repeat the parameter number and name sequence, press **SELECT**. To exit the information mode, press **ZERO**.

Table 29: Information Parameters

PARAMETER	NAME	DESCRIPTION
60000	<i>E2Ins</i>	Total amount of EEPROM storage.
60001	<i>E2Fre</i>	Amount of available EEPROM storage.
60100	<i>-GSE- ~ c1998</i>	Copyright statement.
60101	<i>0350P ~ 01001</i>	Firmware revision code.
60102	<i>02- 10 ~ 1998</i>	Firmware date code.
60200	<i>b sn ~ 10001</i>	Main circuit board serial number.
60201	<i>Audit ~ Trail Euro ~ 00000</i>	OIML (European) audit trail number (see <i>OIML Audit Trail</i> on page 104).
60202	<i>i sn ~ 00000</i>	Model 350/355 serial number.
60203	<i>Audit ~ Trail CAL. ~ 00000</i>	Calibration audit trail number (see <i>Calibration Audit Trail</i> on page 104).
60204	<i>Audit ~ Trail Setup ~ 00000</i>	Setup audit trail number (see <i>Setup Audit Trail</i> on page 104).
61100	<i>Load ~ Cell 0.00000</i>	Current mV/V output of the load cell.
61101	<i>Cal ~ Factr 1.00000</i>	Calibration factor for the load cell.
61102	<i>Rezro ~ Load 0.00000</i>	Amount of weight (in default units) zeroed through use of the  key.
61103	<i>Zrtrc ~ Load 0.00000</i>	Amount of weight (in default units) zeroed by the zero track feature since  was last pressed.
61104	<i>CZero ~ 0P</i>	Coarse zero calculated during calibration.
61105	<i>Fine ~ Zero 1738</i>	Fine zero calculated during calibration.
61106	<i>CGain ~ 50</i>	Coarse gain calculated during calibration.
61107	<i>Fine ~ Gain 1.00000</i>	Fine gain calculated during calibration.
61110 ↓ 61112	<i>Zero ~ Adj25 73741 ↓ Zero ~ Ad100 -21813</i>	A/D compensation for coarse zero.
61117 ↓ 61120	<i>AiN1 ~ NrOff -11035 ↓ AiN8 ~ NrOff -14800</i>	A/D non-ratio-metric offset compensation.
61121	<i>Vref ~ NrOff -12739</i>	A/D reference voltage compensation.
61200	<i>10oFF</i>	Analog option 0 – 10V Zero offset value.
61201	<i>10Gn</i>	Analog option 0 – 10V Full scale gain value.
61202	<i>0oFF</i>	Analog option 0 – 20mA Zero offset value.
61203	<i>0Gn</i>	Analog option 0 – 20mA Full scale gain value.
61204	<i>4oFF</i>	Analog option 4 – 20mA Zero offset value.
61205	<i>4Gn</i>	Analog option 4 – 20mA Full scale gain value.
61206	<i>Srtn</i>	Analog option board serial number.
62000	<i>Dsply ~ Test 8.8.8.8.8.8.</i>	Display test. Press  or  to illuminate all segments. Continue pressing  or  to cycle through various patterns.
62001	<i>Spt 1 ~ Disbl</i>	Allows setpoint status to be changed by pressing  or  while viewing this parameter. Requires that setup was entered using the access code.
62002	<i>Spt 2 ~ Disbl</i>	
62003	<i>Spt 3 ~ Disbl</i>	
62004	<i>Analg ~ 0- 10v</i>	

62005	<i>Analg ~ 0-20A</i>	Allows the analog output to be changed by pressing  or  . Output will toggle through 0, 25, 50 and 100 percent while viewing this parameter. Requires that setup was entered using the access code (see <i>Analog Board Diagnostic and Test Procedures</i> on page 29).
62006	<i>Analg ~ 4-20A</i>	
64000	<i>Send ~ Setup</i>	Transmits all setup information out the communication port.
64100	<i>LnCnt ~ 0</i>	Received setup line count.
64101	<i>ErCnt ~ 0</i>	Received setup error count.
64102	<i>IstEr ~ None!</i>	Parameter of the first setup receive error.
65001	<i>Deflt ~ All</i>	Default All. Sets all parameters to factory default settings. Press  or  to initiate default.
65002	<i>Deflt ~ -CAL</i>	Same as above, except calibration is retained.

A/D Calibration Procedure

The Model 350/355 Analog-to-Digital Converter (A/D) is calibrated at the factory to ensure a stable, linear response to the load cell signal. This calibration procedure calculates critical values that are permanently stored in parameters P61110 – P61121. The A/D calibration should not be confused with the standard weight calibration. It should never be necessary to recalibrate the A/D. However, if the values stored at parameters P61110 – P61121 appear to be reset to 0.00000 and/or 1.00000, then A/D recalibration is necessary. Contact GSE Scale Systems or your local authorized GSE distributor for more information on this procedure.

Part Number 39-10-41432